



	300289

	399	6 1 10 3
	144-164	9 558
158	B	4-1







2014 9 11

49,247.82

70%

25% 24% 13.5% 7.5%

2014 9 11

4,270

70%

31% 30% 9%

2014 12 31

70%

45%

39%



2014 10 15

109

2014

11 24

45%

39%

2014 8 31

100%

75,415.26

II

2014 6 30

5,000

2014 6 30

5,000

45%

31,680

100%

6,105.12

39%

2,379

45%		16,896.00	6,177,697
		9,504.00	3,474,954
		5,280.00	1,930,530
		31,680.00	11,583,181
39%		1,830.00	669,104
		549.00	200,731
		2,379.00	869,835
		34,059.00	12,453,016

70%

58.60%

54.30%

45%

39%

	24%	16,896.00	6,177,697
	30%	1,830.00	669,104
		18,726.00	6,846,801
	13.5%	9,504.00	3,474,954
	9%	549.00	200,731
		10,053.00	3,675,685
	7.5%	5,280.00	1,930,530
		34,059.00	12,453,016

2014

8 31

100%

75,415.26

2014 8 31 13,006.74 62,408.52
479.82%

II

2014 6 30 5,000 2014
6 30

5,000
45% 31,680

100% 6,105.12 2014
8 31 1,864.70 4,240.42 227.40%

39% 2,379

2014 12 31 157,267,000
12,453,016

	56,448,000	35.89%	0	56,448,000	33.26%
	35,712,000	22.71%	0	35,712,000	21.04%
	0	0.00%	6,846,801	6,846,801	4.03%
	0	0.00%	3,675,685	3,675,685	2.17%
	0	0.00%	1,930,530	1,930,530	1.14%
	65,107,000	41.40%	0	65,107,000	38.36%
	157,267,000	100.00%	12,453,016	169,720,016	100.00%

2014 12 31

54.30%

4.03%

2.17%

1.14%

2014

[2015]1550

	2014	2014	%
	161,616.86	191,663.39	18.59%
	96,451.11	134,221.47	39.16%
	53,697.08	69,509.49	29.45%
	16,779.53	21,474.95	27.98%
	12,828.13	16,539.50	28.93%
/	0.84	0.97	15.48%
/	0.81	0.94	16.05%



30

/

		5
		5
		5
		/
		/
		/

3 2014 10 15

13.5%

9%

4 2014 10 15

24%

30%

5 2014 10 15

7.5%

6 2014 10 16

7 2014 11 6

8 2014 11 24

2014

9 2015 4 3

10 2015 4 7

11 2015 4 7

12 2015 4 7

13 2015 4 7

14 2015 4 24

[2007]128

		2014	8	31	100%
	13,006.74			75,415.26	
479.82%	100%			1,864.70	6,105.12
	227.40%				

-10% 10%

10%	89,265.90	0.18	7,238.52	0.19
5%	82,340.58	0.09	6,671.82	0.09
0%	75,415.26	0.00	6,105.12	0.00
-5%	68,489.94	-0.09	5,538.42	-0.09
-10%	61,564.62	-0.18	4,971.73	-0.19

2014 ~2017

5,516

6,342

6,977

7,674



2014

5,687.83

452.56

2014 9 11

49.53%

2014 9 11

20%

10,703.56

10,703.56



20

DiaSys

DiaSys

25%

31%



1

80%

2

3

DiaSys

DiaSys



	2012	2013	2014	
				2012 2013 2014
				2.89 14.43 -19.73
2012	2013	2014		-5.52
	10.73	-217.59		
	2005	7		

20%

3-5

98%



2011 12 6

15%

2014 12 6

3

2014

2014 2016

15%

2017

2013

2013

1,200



II 2014 6 30
5,000 2014 6 30

1,699.50 2014

0.8%



.....	2
.....	4
一、本次交易方案概述	5
二、本次交易构成重大资产重组	7
三、本次交易不构成关联交易	7
四、本次交易不构成借壳上市	8
五、本次交易的支付方式	8
六、标的资产的估值及作价	8
七、本次交易对上市公司的影响	9
八、本次发行股份的价格和数量	10
九、股份锁定期	11
十、业绩承诺及补偿	12
十一、本次重组相关方作出的重要承诺.....	13
十二、本次重组对中小投资者权益保护的安排.....	16
十三、本次交易已履行的和尚未履行的决策及审批程序.....	17
十四、独立财务顾问的保荐机构资格.....	19
.....	20
一、与本次重组相关的风险	20
二、标的资产的经营风险	24
三、其他风险	30
.....	32
.....	37
.....	43
一、本次交易的背景	43
二、本次交易的目的	47
三、本次交易的决策过程和批准情况.....	51
四、本次交易方案	53
五、本次交易对上市公司的影响	55

六、本次交易不构成关联交易	57
七、本次交易构成重大资产重组	57
八、本次交易不构成借壳上市	58
.....	59
一、上市公司基本信息	59
二、公司设立及上市情况	60
三、公司首次公开发行并上市后股本变动情况.....	65
四、上市公司控制权变动情况	66
五、控股股东及实际控制人	66
六、最近三年主营业务发展情况	68
七、最近三年的主要财务数据	69
八、最近三年重大资产重组情况	70
九、上市公司遵纪守法情况	70
.....	71
一、本次交易对方总体情况	71
二、发行股份购买资产交易对方详细情况.....	72
三、交易对方及其主要管理人员最近五年的诚信情况.....	88
.....	90
一、德赛系统基本情况	90
二、德赛产品基本情况	113
三、标的公司其他情况	127
四、标的公司合法合规情形	174
.....	176
一、本次重组方案	176
二、本次发行股份具体情况	178
三、本次发行股份前后主要财务数据比较.....	181
四、本次发行股份前后公司股本结构变化.....	182
五、本次交易未导致公司控制权发生变化.....	183
.....	184
一、德赛系统 45%股权的评估情况.....	184
二、德赛产品 39%股权的评估情况.....	216

三、发行股份购买资产股份发行定价合理性分析.....	232
四、董事会对本次评估事项的意见.....	234
五、独立董事对本次评估事项的意见.....	248
.....	250
一、合同主体及签订时间	250
二、《重大资产重组框架协议》及《发行股份购买资产协议》	250
三、《业绩补偿协议》及《业绩补偿协议的补充协议》	254
四、《技术和产品合作协议》	259
.....	265
一、本次交易符合《重组管理办法》第十一条规定.....	265
二、本次交易符合《重组管理办法》第四十三条规定.....	272
三、上市公司不存在《创业板上市公司证券发行管理暂行办法》第十条规定的不得非公开发行股票的情形	276
.....	278
一、本次交易前上市公司财务状况和经营成果分析.....	278
二、标的公司行业特点和经营情况的讨论与分析.....	283
三、财务状况分析——德赛系统	313
四、盈利能力分析——德赛系统	319
五、财务状况分析——德赛产品	324
六、盈利能力分析——德赛产品	329
七、本次交易对上市公司影响的分析.....	332
.....	341
一、标的公司财务信息	341
二、标的公司盈利预测	344
三、上市公司备考盈利预测	346
四、上市公司备考审计报告	348
.....	353
一、本次交易对同业竞争的影响	353
二、本次交易对关联交易的影响	353
.....	369
一、本次交易完成后上市公司的治理结构.....	369

二、本次交易完成后上市公司的独立性.....	370
.....	372
一、与本次重组相关的风险	372
二、标的资产的经营风险	376
三、其他风险	382
.....	384
一、本次交易完成后，不存在上市公司资金、资产被实际控制人或其他关联人占用的情形，不存在为实际控制人及其关联人提供担保的情形.....	384
二、上市公司在最近十二个月内发生资产交易情况.....	384
三、关于本次表决权委托相关事宜的说明.....	387
四、标的公司的独立性及其持续经营能力.....	387
五、德国德赛退出对标的公司的影响.....	398
六、本次交易完成后上市公司将采取的现金分红政策.....	402
七、关于本次交易相关人员买卖上市公司股票的情况.....	404
八、上市公司停牌前股价无异常波动的说明.....	409
九、本次交易的相关主体和证券服务机构不存在依据《关于加强上市公司重大资产重组相关股票异常交易监管的暂行规定》第十三条不得参与任何上市公司重大资产重组的情形	410
十、对股东权益保护的安排	411
十一、已披露有关本次重组的所有信息的说明.....	412
.....	413
一、独立董事意见	413
二、独立财务顾问意见	414
三、律师意见	415
.....	417
一、独立财务顾问	417
二、律师	417
三、审计机构	417
四、资产评估机构	418
.....	419
一、董事声明	419

二、独立财务顾问声明	420
三、律师声明	421
四、审计机构声明	422
五、评估机构声明	422
六、华普天健会计师事务所（特殊普通合伙）声明.....	424
七、监事声明	425
八、高管声明	426
.....	427
一、备查文件目录	427
二、备查地点	428

/ /		300289	
/			
		DiaSys Diagnostic Systems GmbH/	
		DiaSys Diagnostic Systems (Hong Kong)Co., Limited	
		DiaSys Japan Kabushiki Kaisha, Kobe	
		DiaSys Mongolia Co., Ltd	
/		45%	39%
			45%
		39%	

		45% 39%
/		
		45% 39%
/		
		2014 11 6
		2014 10 16
		2014 11 6
		DiaSys Diagnostic Systems GmbH
		2014 10 16 DiaSys Diagnostic Systems GmbH

		109
		54
		2014
		[2008]14
		[2008]14
26		26
/		
		2014 8 31
		2014 12 31
/		
/		2012 2013 2014

IVD		in vitro diagnostic products
DiaSys		2014

		B
		500
/		
CE		Conformite Europeenne CE

		CE	CE

Kalorama

2007	10.15	2012	21.75
16.47%		6.07%	
2012		3.86%	
			2010
184.5	2012	221	9%
2010	137	2012	150
		2012	29
	8,000		6%
	15%~20%		2015

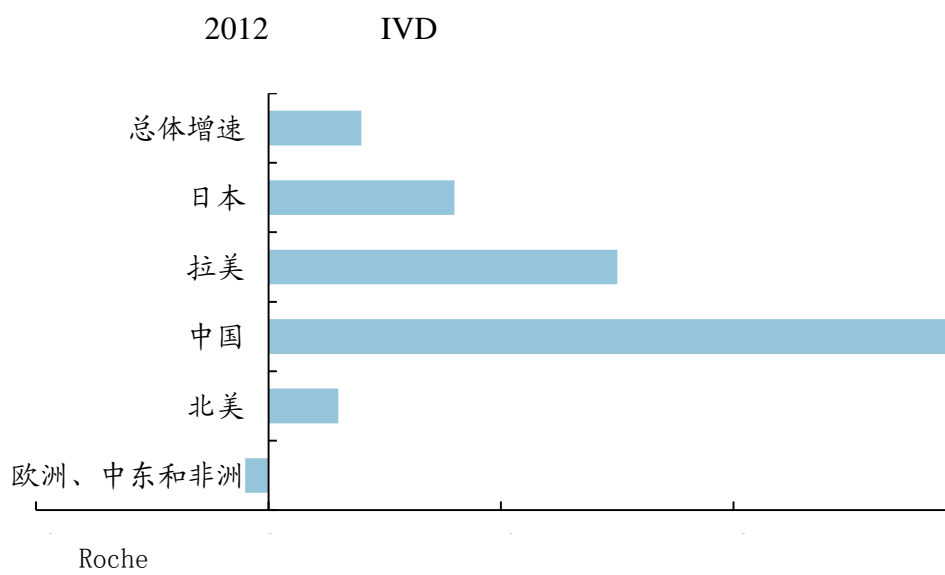

我国体外诊断试剂市场需求增长驱动因素

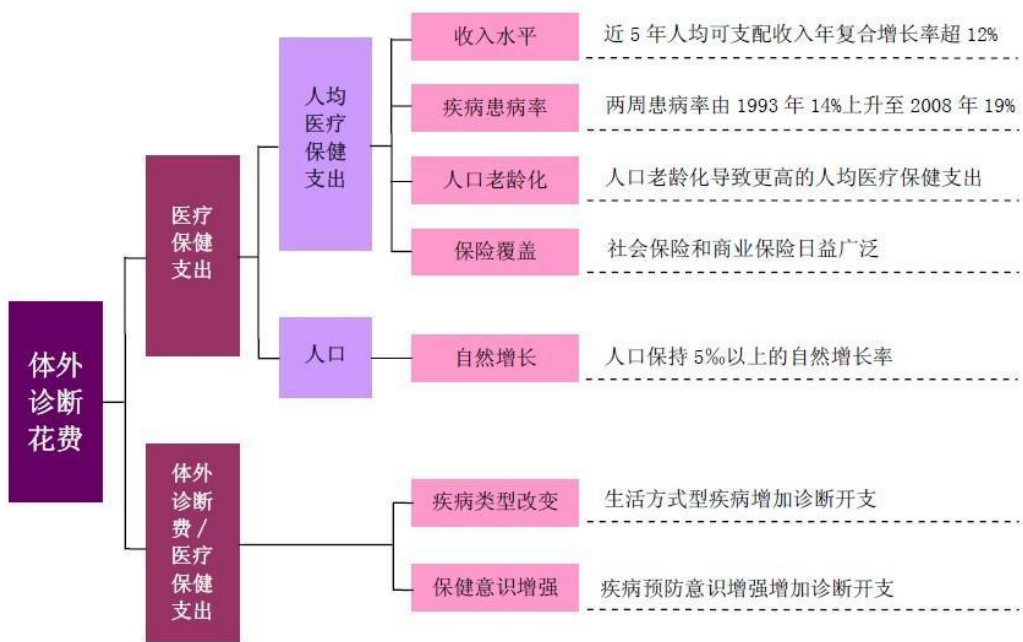

2012

Business Insights

Healthcare	Abbott	J&J	Roche Diagnostics	Siemens
Becton Dickinson		BioMerieux		Beckman Coulter
Sysmex	Bio-Rad			Bayer Diabetes
				22%

15%

20 90



			1991		
				CE	
	1997				DiaSys
		50	74%		2009
		10%			2013
2014		2.14		5,942	
	7,878	476	2013		
2.12	4,148			7,506	448

2012 2

2012



32%

50%

2013

MB

A1

B



1

2

3

50
10%

74%

2009

300



4

IVD

5

6

1

40%

2

2014

21,418.53

39.89%

5,942.33

46.32%

7,505.86

14.67%

475.56

3.71%

1 2014 10 15

1

1 10
ΑΒΦ -s`ΟΕμSàâκ€ κ ^t8°
l
E P

10 2015 4 7

11 2015 4 7

12 2015 4 7

13 2015 4 7

14 2015 4 24



2014 10 15

109

2014

11 24

45%

39%

2014 8 31

100%

75,415.26

II 2014 6 30 5,000

2014 6 30

5,000

45% 31,680

100% 6,105.12

39% 2,379

45%		16,896.00	6,177,697
		9,504.00	3,474,954
		5,280.00	1,930,530
		31,680.00	11,583,181
39%		1,830.00	669,104
		549.00	200,731
		2,379.00	869,835
		34,059.00	12,453,016

70%

70%

2014 12 31 157,267,000

12,453,016

	56,448,000	35.89%	0	56,448,000	33.26%

	35,712,000	22.71%	0	35,712,000	21.04%
	0	0.00%	6,846,801	6,846,801	4.03%
	0	0.00%	3,675,685	3,675,685	2.17%
	0	0.00%	1,930,530	1,930,530	1.14%
	65,107,000	41.40%	0	65,107,000	38.36%
	157,267,000	100.00%	12,453,016	169,720,016	100.00%

2014 12 31

54.30%

4.03%

2.17%

1.14%

2014

[2015]1550

	2014	2014	%
	161,616.86	191,663.39	18.59%
	96,451.11	134,221.47	39.16%
	53,697.08	69,509.49	29.45%
	16,779.53	21,474.95	27.98%
	12,828.13	16,539.50	28.93%
/	0.84	0.97	15.48%
/	0.81	0.94	16.05%

58.60%

54.30%

	Beijing Leadman Biochemistry Co.,Ltd.
	1997 11 5
	110000410125421
	110192600067719
	60006771-9
	153,600,000
	300289
	www.leadmanbio.com
	leadman@leadmanbio.com
	100176
	5
	5
	-6840 -6840-3 6840-2 2015 01 19
	02 19 2019

153,600,000

1997 11 5
 [1997]115

G.T. 15.00
 012542
 1997 12 20 1998 2 10
 97 02-096 98 2-008

		%
G.T.	7.65	51.00
	7.35	49.00
	15.00	100.00

1 2001

2001 7 4 2001
 270
 G.T. 51% 12 Seitz Far East
 GmbH
 2001 10 18

		%
	7.65	51.00
	7.35	49.00

	15.00	100.00
--	--------------	---------------

2 2004

2004 7
[2004]2230

125

2004 9 9

[2004] 1020

2004 9 16

		%
	63.75	51.00
	61.25	49.00
	125.00	100.00

3 2005

2005 7 1

[2005]2245

225

2005 7 29

[2005] 0014

2005 8 4

		%
	114.75	51.00
	110.25	49.00
	225.00	100.00

4 2009

2009 6 18
 [2009]89

a. 49%

b.

51%

11

2009 6 23

110000410125421

225

18,576,079.25

			%
1		9,102,278.83	49.00
2		5,758,603.15	31.00
3		1,083,598.43	5.83
4		712,076.85	3.83
5		619,196.45	3.33
6		318,895.55	1.72
7		247,674.86	1.33
8		226,015.16	1.22
9		176,472.75	0.95
10		173,370.55	0.93
11		117,642.31	0.63
12		40,254.36	0.22
		18,576,079.25	100.00

5 2009 7

2009 6 29

2009

6 30

81,586,099.01

7,200

2009 7 12

[2009]0008

2009 7 21

110000410125421

			%
1		3,528.00	49.00
2		2,232.00	31.00
3		420.00	5.83
4		276.00	3.83
5		240.00	3.33
6		123.60	1.72
7		96.00	1.33
8		87.60	1.22
9		68.40	0.95
10		67.20	0.93
11		45.60	0.63
12		15.60	0.22
		7,200.00	100.00

6 2011 3

2011 2 25

2010

2010 12 31

7,200

10

1.5

1,080

10

5

10

1

7,200

11,520

2011 2 28

[2011]0019

			%
1		5,644.80	49.00
2		3,571.20	31.00
3		672.00	5.83
4		441.60	3.83
5		384.00	3.33
6		197.76	1.72
7		153.60	1.33
8		140.16	1.22
9		109.44	0.95
10		107.52	0.93
11		72.96	0.63
12		24.96	0.22
		11,520.00	100.00

2012 2

11,520

15,360

2011 5 10

2011

2011 12 30

[2011]2142

2012 2 8

38,400,000

13.00

38,400,000.00

153,600,000.00

2012 2 13

[2012]0358

			%
1		5,644.80	36.75
2		3,571.20	23.25
3		672.00	4.38
4		441.60	2.88
5		384.00	2.50

35,712,000

22.65%

56,448,000

35.80%

92,160,000

58.45%

2012

1

2014 12 31

5,644.80

35.89%

80% 20%

3,571.20

22.71%

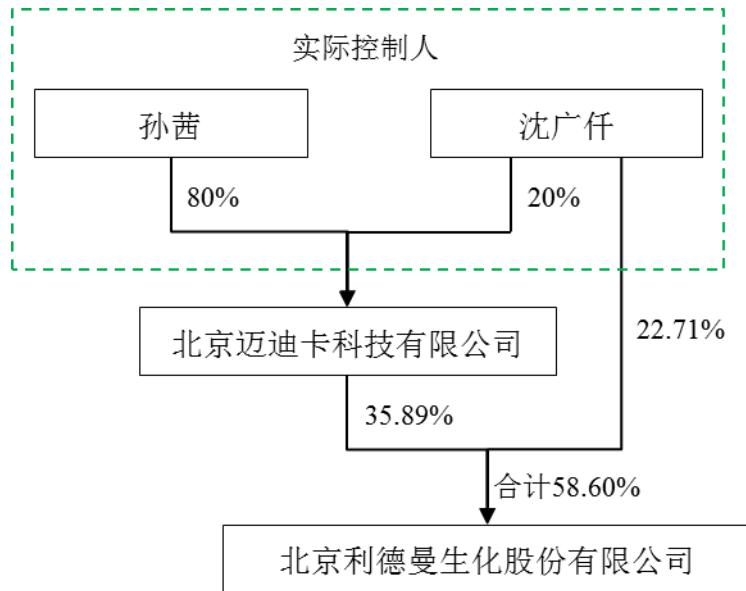

2

1

116

35

13

33

2014 7

CI1000

180 /

4

10-19

1

	2014		2013		2012	
	52,001.28	97.63%	34,155.10	99.39%	31,668.45	99.88%
	1,259.66	2.37%	207.93	0.61%	38.93	0.12%
	53,260.94	100.00%	34,363.02	100.00%	31,707.38	100.00%

2

	2014		2013		2012	

	48,033.79	90.19%	29,286.37	85.23%	27,117.43	85.52%
	1,468.66	2.76%	1,176.33	3.42%	1,093.37	3.45%
	3,758.48	7.06%	3,900.32	11.35%	3,496.58	11.03%
	53,260.94	100.00%	34,363.02	100.00%	31,707.38	100.00%

2014 53,697.08 56.26%
16,779.53 30.83% 2013 34,363.02
8.31% 12,825.85 11.70%

[2013]0518

[2014]0807

[2015]0706

2012 2013 2014

1

	2014 12 31	2013 12 31	2012 12 31
	161,616.86	124,398.40	113,018.93
	52,347.89	39,286.04	36,916.97
	109,268.97	85,112.36	76,101.96

2

	2014 1-12	2013 1-12	2012 1-12
	53,697.08	34,363.02	31,727.38
	16,779.53	12,825.85	11,482.24
	12,828.13	11,007.20	9,828.71

3

	2014	12	31	2013	12	31	2012	12	31
%			32.39			31.58			32.66
/			6.13			5.54			4.95
-	/		0.84			0.72			0.67
%			13.30			12.93			12.92

45%

39%

1		30.0	25.0%
2		28.8	24.0%
3		26.4	22.0%
4		16.2	13.5%
5		9.0	7.5%
6		6.0	5.0%
7		3.6	3.0%
		120.0	100.0%

1		15.5	31.0%
2		15.0	30.0%
3		15.0	30.0%
4		4.5	9.0%
		50.0	100.0%

1

	399 6 1 10 3
	510109000469307
	51019839672985x
	39672985-X

	2014 7 25

2

2014 7 25

10

2014 7 25

510109000469307

		1.5	15.00%
		0.5	5.00%
		0.3	3.00%
		0.3	3.00%
		0.5	5.00%
		1	10.00%
		1	10.00%
		0.3	3.00%
		2.5	25.00%
		1	10.00%
		1	10.00%
		0.1	1.00%

		10.00	100.00%

3

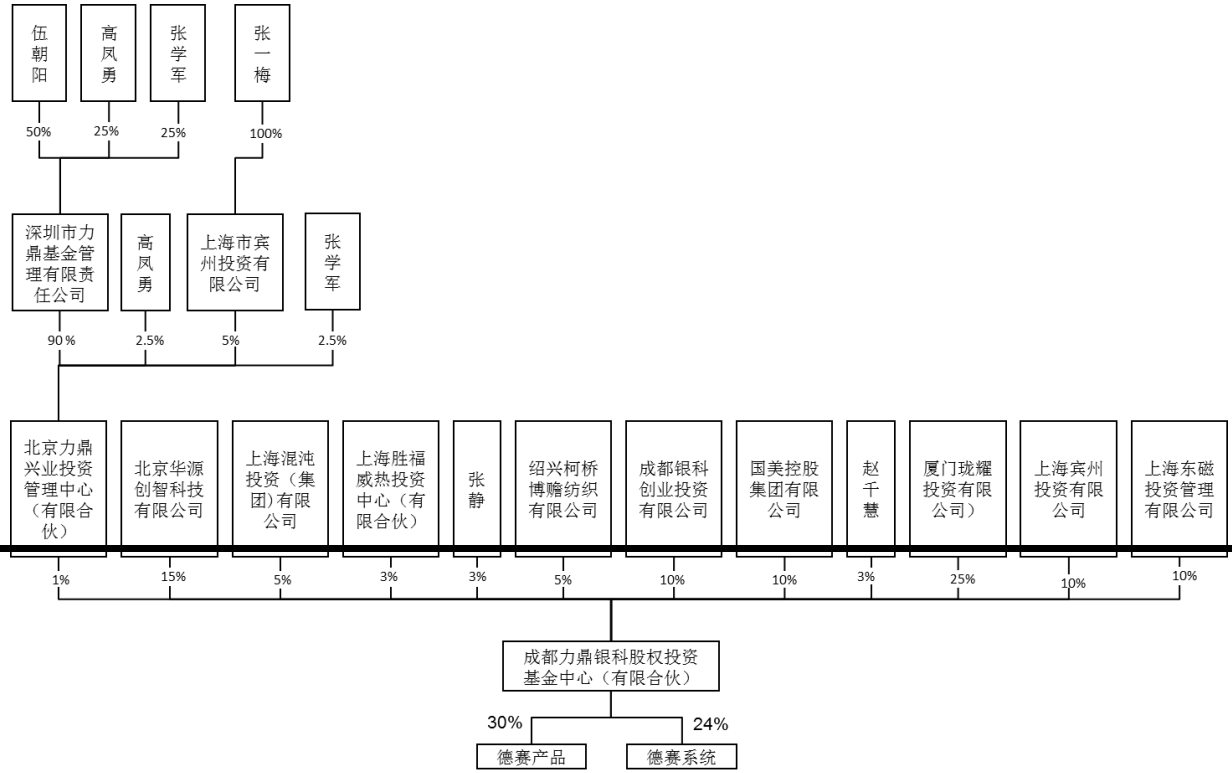

4

1 700P

	110102012786440
	51019839672985X
	39672985-X
	2010 4 16

		90.00	90.00%
		5.00	5.00%
		2.5	2.50%
		2.5	2.50%
		100.00	100.00%

2015 3 2 A

2015 0081 2014 3 3 A 2014

0127 2013 3 13

[2013] 207

	2014 12 31	2013 12 31	2012 12 31
	83,654,911.01	102,991,517.15	88,424,322.93
	77,769,964.67	96,084,986.67	86,739,418.35
	5,884,946.34	6,906,530.48	1,684,904.58

	2014 1-12	2013 1-12	2012 1-12
--	-----------	-----------	-----------

	20,536,540.80	22,383,139.39	16,832,012.66
	4,965,494.62	5,809,161.34	2,331,497.51
	4,386,072.84	5,720,888.95	2,331,497.51

/

/4/ 1 /

8

1		0.148%	
2		5.185%	
3		5.005%	
4		5.162%	
5		0.686%	
6		2.321%	
7		0.000001%	
8		80%	

2

	601
	1000.00
	350212200057698

	2012 11 29
3	
	2 5 20616-A0120
	100.00
	110101014080628
	2011 07 20

4

12010419640915*****

EMBA 1992

5

24%

30%

6

7

2015 2 5 A

2015 0010 2014 7 25 2014

12 31

	2014 12 31		2014 1 -12
	254,590,321.94		0.00
	4,193,400.98		-1,603,079.04
	250,396,920.96		-1,603,079.04

1

		144-164	9 558
	310000000123958		
	310115088493304		
	08849330-4		
	2014 3 11		

2

1

2014 3 11

10.2

2014 3 11

310000000123958

--	--	--	--

		0.1	0.98%
		4.9	48.04%
		3	29.41%
		2.2	21.57%
		10.2	100.00%

2

2014 8

105,000

3,000 2014

8 31

310000000123958

		0.1	0.95%
		4.9	46.67%
		3.0	28.57%
		2.2	20.95%
		0.3	2.86%
		10.5	100.00%

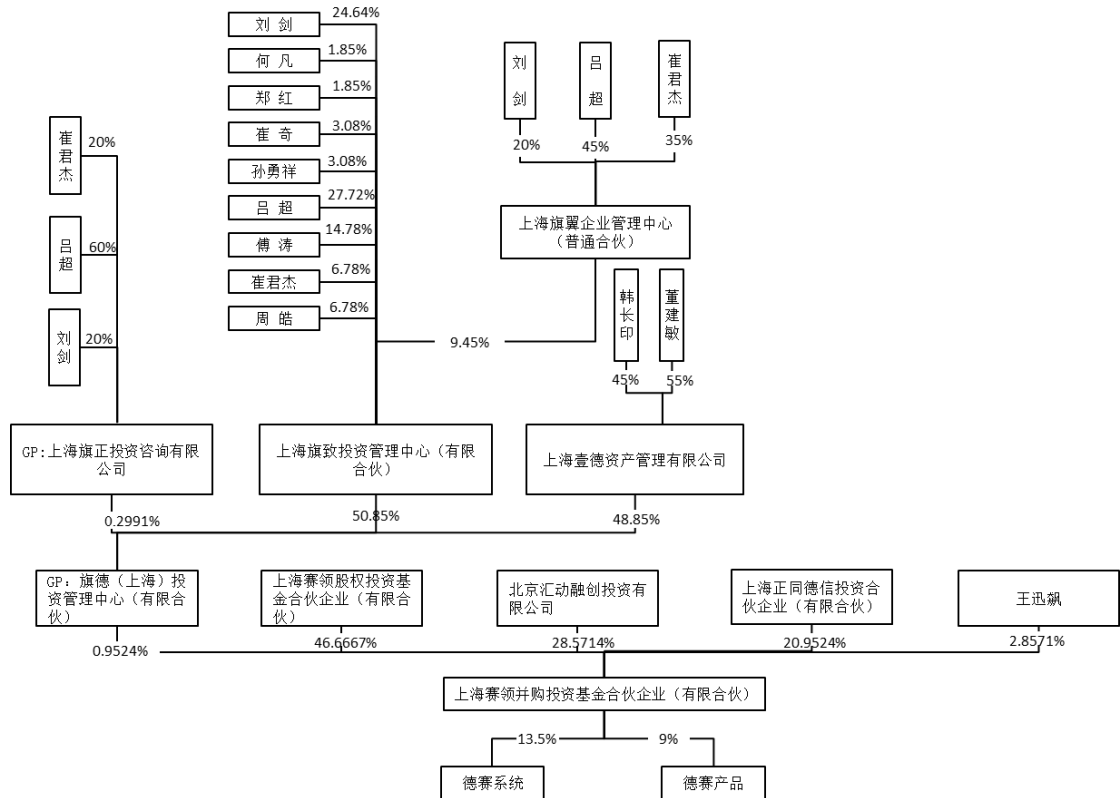

4

1

-

	2777 1026B
	310115002215245
	310115086159732
	08615973-2
	2013 12 9

		3.00	0.30%
		510.00	50.85%
		490.00	48.85%
		1003.00	100.00%

	2014 12 31		2014 1-12
	3,009,281.09		0
	30.50		9.17
	3,009,250.59		9.17

/

/4/ 1 /

	88 1 128A
	JAMES XIAO
	DONG LIU
	310000000120481
	2013 9 12

	8 410 -270
	1009
	110228012531216
	2010 1 4

	2123 3E-1539
	310115001818764
	2011 4 28

11010819620214****

4

13.5%

9%

2

1		99.98%	
2		99.995%	

5

6

	2014 12 31		2014 3 -12
	328,011,013.98		6,175,123.93
	0		-7,988,986.02
	328,011,013.98		-7,988,986.02

	158	B	4-1
	540091200012027		

	54018397687778
	39768777-8
	2014 7 23

2

2014 7 19

3.7

		0.1	2.70%
		0.3	8.11%
		0.5	13.51%
		0.3	8.11%
		0.5	13.51%
		0.5	13.51%
		0.5	13.51%
		0.5	13.51%
		0.5	13.51%
		3.7	100.00%

2014 7 23

540091200012027

2014 11 3

		0.1	2.5%
		0.3	7.5%
		0.8	20%
		0.5	12.5%
		0.5	12.5%
		0.5	12.5%
		0.5	12.5%
		0.8	20%
		4	100.00%

3

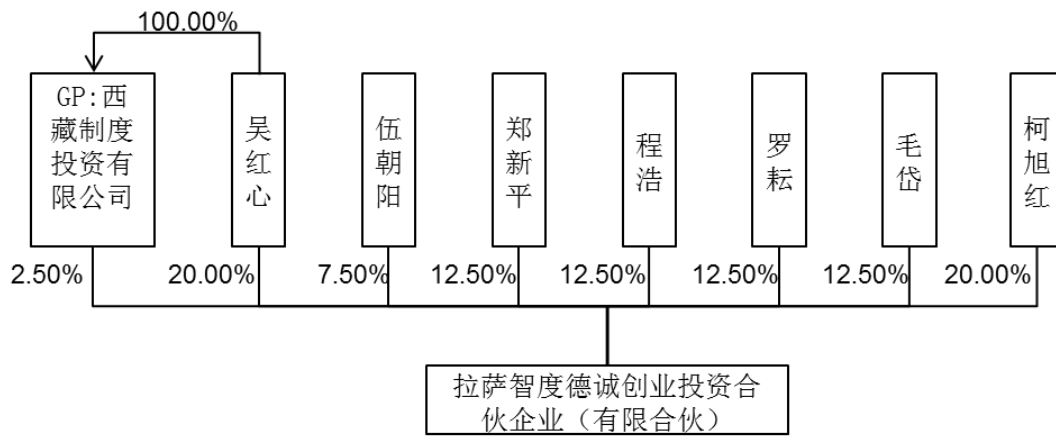

4

1

-

	158 B 3 2 4-1
	540091200012019

	540108397686572
	39768657-2
	2014 07 18

	12011319680316****
	1 1 302
	2 31F

	2004 9 1		82.95%

	/	%
	25,800.00	82.95
	5,400.00	52.00
	8,531.95	7.87
	15,848.96	0.83
	700.00	52.35
	1,000.00	100.00

	40,000.00	20.00
	1,000.00	20.00
	24,001.00	50.00
	50,010.00	99.98
	33,500.00	2.99
	61,800.00	8.09
	17,500.00	11.43
	150,678.75	15.08
	7,500.00	2.80
	100.00	5.00

2

12010419640915****

18

12-10B

120113119680316****

18

33072219691022****

16 3 402

11010219690121****

30

33010219671110****

232 9

32062519620519****

179

11010119660501****

8

4-A-809

4

7.5%

9.27%

5

6

	2014 12 31		2014
	615,953,715.15		0
	662,981.76		-2,208,707.01
	615,290,733.39		-2,208,707.01

1

2

3

G ünther Jans

30 40

1999 12 9

99 1377

1999 12 16

[1999]1498

1999 12 28

026667

1999 12 28

2000 5 11 2000

808 2000 5 9

2000 5 18

026667

30

1		14.70		49.00%
2		12.30		41.00%
3	G ünther Jans	3.00		10.00%
		30.00		100.00%

2

1 2003 6

2001 10 23

49%

2002 5 8

49%

19.6

14.7

4.9

2003 6 3

2003 747

2003 6 10

[1999]1498

1		14.70		49.00%
2		12.30		41.00%
3	Günther Jans	3.00		10.00%
		30.00		100.00%

2 2006 8

2005 9 1

49%

422.40

G nther Jans

2005 9 28

G nther Jans

49%

G nther Jans

422.4

2006 7 26

[2006] 2808

2006 8 7

[1999]1498

2006 8 17

026667

1	Günther Jans	17.70		59.00%
2		12.30		41.00%
		30.00		100.00%

3 2007 12

2007 10 19

30

120

40

168

2007 11 26

[2007]

1	Günther Jans	70.80		59.00%
2		49.20		41.00%
		120.00		100.00%

4 2013 4

2012 3 18 Günther Jans 5

2011 12 31

59%

				%	
1	Günther Jans		2,904,607.80	16	19.2
2			3,993,835.73	22	26.4
3			2,178,455.85	12	14.4
4			544,613.96	3	3.6
5			544,613.96	3	3.6
6			544,613.96	3	3.6
			10,710,741.26	59	70.8

2013 3 29

[2013] 251

2013 4 1

[1999]1498

2013 4 22

310000400229163

1		68.40		57.00%
2		26.40		22.00%
3		14.40		12.00%
4		3.60		3.00%
5		3.60		3.00%
6		3.60		3.00%
		120.00		100.00%

5 2014

2014 9 11

100%

70,400

70%

492,478,217.10

25% 24% 13.5%

7.5%

		%			
1		9	63,360,000	63,318,627.91	
		5	35,200,000	35,177,015.51	
		13.5	95,040,000	94,977,941.87	
		7.5	52,800,000	52,765,523.26	
2		12	84,480,000	84,424,837.22	
		7	49,280,000	49,247,821.71	
3		7	49,280,000	49,247,821.71	
4		3	21,120,000	21,106,209.30	
5		3	21,120,000	21,106,209.30	

6		3	21,120,000	21,106,209.30	
---	--	---	------------	---------------	--

2014 9 19

[2014] 939

2014 9 22

[1999]1498

2014 9 23

310000400229163

2014 12 31

70%

1		30.00		25.00%
2		28.80		24.00%
3		26.40		22.00%
4		16.20		13.50%
5		9.00		7.50%
6		6.00		5.00%
7		3.60		3.00%
		120.00		100.00%

1



2

2015-2017

2015

2017



1

2

3

4

1

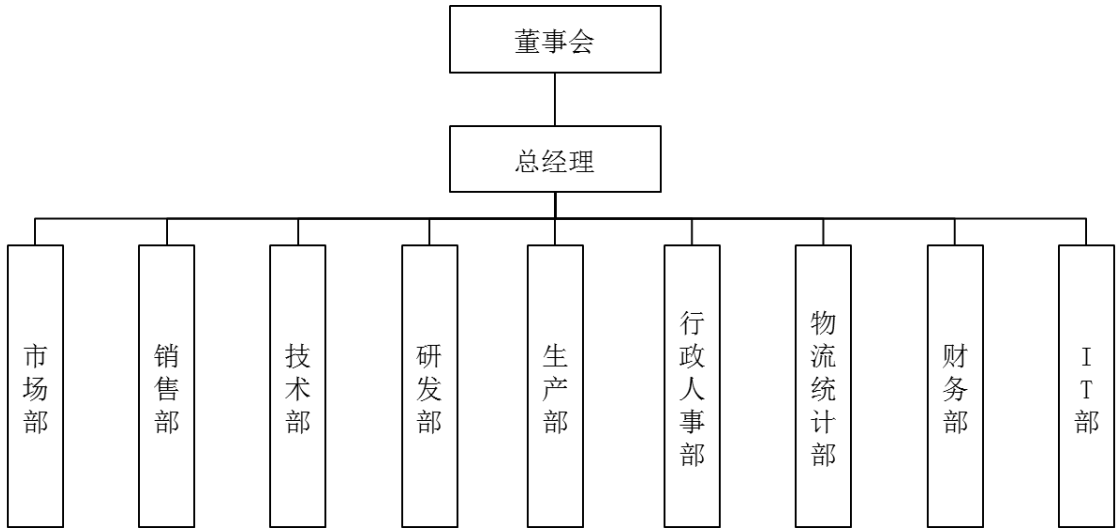

9

IT	

2

2014 12 31

75

1

2014 12 31

	3	4.00%
	12	16.00%
	8	10.66%
	32	42.66%
	9	12.00%
	4	5.33%
	1	1.34%
	4	5.34%
	2	2.67%
	75	100.00%

2

2014 12 31

	11	14.66%
	36	48.00%
	24	32.00%

	4	5.34%
	75	100.00%

3

2014 12 31

30	28	37.33%
30 -40	31	41.33%
40 -50	7	9.34%
50	9	12.00%
	75	100%

() (14) S0190

[2015]0710

1

	2014	12	31	2013	12	31	2012	12	31
			148,559,570.02			118,279,613.04			94,412,513.50
			33,411,000.84			37,205,527.11			34,439,131.40
			181,970,570.86			155,485,140.15			128,851,644.90
			78,717,686.29			47,409,338.52			57,016,165.35
			970,000.00			270,000.00			510,000.00
			79,687,686.29			47,679,338.52			57,526,165.35
			102,282,884.57			107,805,801.63			71,325,479.55
			0			0			0
			102,282,884.57			107,805,801.63			71,325,479.55

2

2014	2013	2012
214,185,274.22	212,132,748.14	183,917,914.29
97,442,185.01	102,246,904.31	103,594,127.30
68,678,746.90	43,609,859.63	38,935,430.92
59,423,340.01	41,480,322.08	33,390,244.00
2,545,038.50	2,329,485.43	813,207.02
56,878,301.51	39,150,836.65	32,577,036.98

3

2014	2013	2012
43.79%	30.66%	44.65%
54.51%	51.80%	43.67%
27.74%	19.55%	18.15%
58.10%	38.48%	46.81%

2013

2012

2013

2013

2012

2014

2013

4

2014	2013	2012
-------------	-------------	-------------

	0.00	-44,554.13	-148,641.94
	3,025,788.70	2,760,319.63	1,111,368.61
	-31,625.76	24,805.59	-6,012.53
	2,994,162.94	2,740,571.09	956,714.14
	449,124.44	411,085.66	143,507.12
	2,545,038.50	2,329,485.43	813,207.02

2015

1

2014 12 31

	50,494,874.52	27.75%	
	60,181,833.10	33.07%	
	678,031.54	0.37%	
	18,150,086.93	9.97%	
	18,278,540.49	10.04%	
	28,161,973.09	15.48%	

1

--	--	--	--	--	--	--

	588 1-28	2009 003207	1,563.64	48,965	2009.2.17-20 56.12.30	
	222 2-21 9	2012 254428	2,079.98	25,545	2012.3.23-20 58.12.10	

2

1		A1		ZL201010022923.9	2010-01-18	2014-2-26
2				ZL201020242276.8	2010-06-28	2011-6-22
3				ZL201320250450.7	2013-05-09	2013-11-13
4				ZL201320269437.6	2013-05-16	2013-10-09
5				ZL201320259303.6	2013-05-13	2013-10-02
6				ZL201020518992.4	2010-09-07	2011-02-16
7				ZL201020512512.3	2010-09-01	2011-03-16
8				ZL201320258745.9	2013-05-13	2013-10-09
9				ZL201320249120.6	2013-05-09	2013-10-09
10				ZL201320258764.1	2013-05-13	2013-10-09
11				ZL201020509059.0	2010-08-30	2011-04-20
12				ZL201020509059.0	2010-09-27	2011-04-20
13		SAA1 β / β /		ZL 201110418922.0	2011-12-15	2014-12-17

DiaSys

6342912	Innova Star		9		2010.03. 28
6449046	Innova Star		10		2010.03. 07
IR625722	DIASYS		1,5,9,42	/	1994.09.10
1168173	TruLab		1,5		2013.07.20
IR718941	TruCal		1,5		1999.06.09

	/			
1	www.diasys.cn		2003.03.17	2016.03.17

50

7

12500	10
1255050)
32500	
18830	
18610	A
18650	B
12511	

2

2014 12 31

	16,512,448.42	20.72%	
	19,730,000.00	24.76%	
	6,543,746.29	8.21%	
	1,366,979.65	1.72%	
	33,005,000.00	41.42%	
	1,559,511.93	1.96%	

3

2014 12 31

2012

015

2012 254428

1,000

2012 4 5

2017 4 5 2014 12 31

2009 003207

1,500 2013 3 19 2016 3 18
2014 12 31

2014 6 30 Commerzbank AG
Limburg Branch 255

Branch Commerzbank AG Shanghai
2,500

2014 10 24

Letter of Cancellation

2,500 2014 10 24

1

2014 9 11

2014 6 30

100%

70,400

2014 6 30

12,068.35

58,331.65

2014 8 31

100%	75,415.26	2014	6	30
5,015.26	7.12%		2014	6 30

1

	respons@920	respons@910	
respons@940	InnovaStar®		
respons@920	respons@910	InnovaStar®	
	2015	respons@940	2014
	2015		2016

respons@920			
	200 /	360 /	ISE
	30		

respons@920

2014 9 11

2011 12 6

GR201131000672

15%

2014

2014

15%

2014 9 11

25%

2

respons®920

respons®910

respons®940

InnovaStar®

12%

2

1

/

2

100%

	2013 4	2014 9	
100%	1,815.38	70,354.03	70,400.00
	-	3775.44%	0.07%

2013 4

2012 3 18

G nther Jans

5

2011 12 31
59%

2012 12 31
16% 22% 12% 3% 3% 3%

G ünther Jans

2012 12 31

				%
1	G ünther Jans		2,904,607.80	16
2			3,993,835.73	22
3			2,178,455.85	12
4			544,613.96	3
5			544,613.96	3
6			544,613.96	3
			10,710,741.26	59

2013 4 22

310000400229163

2006 49%

G ünther Jans

G ünther Jans

49%

G ünther Jans

2013 4

Günther Jans

Günther Jans

2011 12 31
1,728.93 5% 1,815.38
4

2014 9
70% 49,247.82
25% 24% 13.5% 7.5%

2014 9 11

--	--	--	--	--

				%
1			63,318,627.91	9
			35,177,015.51	5
			94,977,941.87	13.5
			52,765,523.26	7.5
2			84,424,837.22	12

253 4# 2 A

253 4# 2 A

50

50

310115400248195

310141677851325

67785132

[

]

2008 08 21

2008 08 21 2038 08 20

1

2008 7 25

[2008]58 2008 7

30

[2008]2170

2008 8 21

310115400248195

2008 8 21

2008 11 12

2008 2080

2008 10 15

164,799.7

2010 8 6

2010 023

2010 7 28

335,200.30

2010 8 9

310115400248195

50

1		30.00		60.00%

2	Günther Jans	20.00		40.00%
		50.00		100.00%

2

1 2013 7

2013 1 11 Günther Jans Günther
Jans 40% 5,313,920

2013 4 28

[2013]304 2013

5 2

[2008]2170 2013 7 26

310115400248195

1		50.00		100.00%
		50.00		100.00%

2014 9 16

No.007587

2014 9 18

310000400229163

2014 12 31

70%

1		15.50		31.00%
2		15.00		30.00%
3		15.00		30.00%
4		4.50		9%
		50.00		100.00%

1

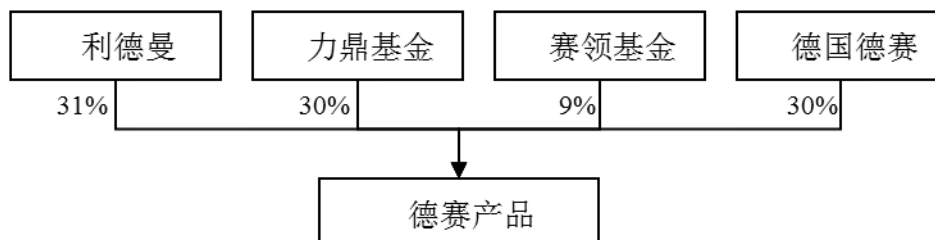

2

2015-2017

2015-2017

2014 10 15

3

1

2

3



1

2

3

4

1

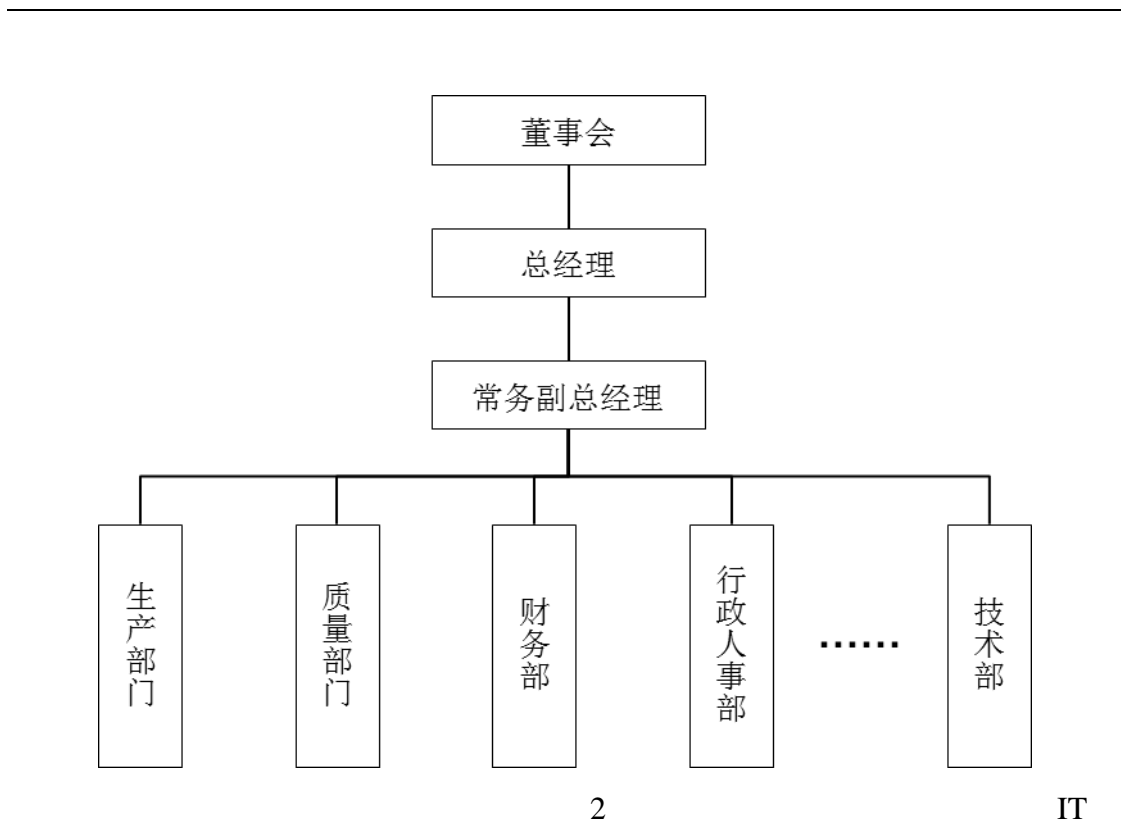

/
/1

/

2

2014 12 31

28

1

2014 12 31

	1	3.57%
	1	3.57%

	25	89.29%
	0	0%
	1	3.57%
	28	100.00%

2

2014 12 31

	8	28.58%
	11	39.28%
	9	32.14%
	28	100.00%

3

2014 12 31

30	9	32.14%
30 -40	11	39.28%
40 -50	4	14.29%
50	4	14.29%
	28	100%

() (14) S0191

[2015]0711

1

	2014	12	31	2013	12	31	2012	12	31
	41,088,579.14			27,529,792.31			31,683,557.23		
	2,101,086.64			1,965,888.08			2,177,434.72		
	43,189,665.78			29,495,680.39			33,860,991.95		
	21,291,620.81			12,353,243.24			14,438,302.28		
	0			0			0		
	21,291,620.81			12,353,243.24			14,438,302.28		
	21,898,044.97			17,142,437.15			19,422,689.67		
	0			0			0		
	21,898,044.97			17,142,437.15			19,422,689.67		

2

	2014	2013	2012
	78,786,715.76	75,058,588.17	77,052,359.53
	65,132,454.59	64,057,046.83	66,414,202.08
	6,054,235.78	5,771,323.35	7,327,823.20
	4,755,607.82	4,481,499.80	5,639,639.90
	229,992.37	174,766.79	171,587.42
	4,525,615.45	4,306,733.01	5,468,052.48

3

	2014	2013	2012
	49.30%	41.88%	42.64%
	17.33%	14.66%	13.81%
	6.04%	5.97%	7.32%
	21.72%	26.14%	29.04%

2014

4

	2014	2013	2012
	0.00	-17,506.80	-24,443.77
	288,000.00	251,500.00	253,227.00
	18,656.49	-970.81	-
	306,656.49	233,022.39	228,783.23
	76,664.12	58,255.60	57,195.81
	229,992.37	174,766.79	171,587.42

1

2014 12 31

	10,373,274.30	24.02%	
	21,268,937.27	49.25%	
	1,743.00	0.00%	
	202,046.10	0.47%	
	9,040,238.05	20.93%	
	2,006,086.64	4.64%	

1

2

1			253 4 2 A C	1467.70	2013.3.1-201 8.2.28	2000 006929
2			253 4 2 B	745	2013.10.18-2 018.10.17	2000 006929

2

DiaSys

/ /1 / 2 /

2

2014 12 31

	4,152,167.39	19.50%	
	380,000.00	1.78%	
	633,700.92	2.98%	
	16,125,752.50	75.74%	

3

1

2014	9	11		2014	6	30
			100%			6,100
2014	6	30	1,847.87			4,252.13
			2014	8	31	
100%		6,105.12	2014	6	30	5.12
		0.084%	2014	6	30	

1

						respons®920
		respons®910		respons®940		InnovaStar®
				respons®920		respons®910
		InnovaStar®				2015
respons®940		2014				2015
		2016				
		respons®920				
		200	/			360 / ISE
		30				

respons@920

2014 9 11

2

respons@920
InnovaStar®

respons@910

respons@940

12%

2

1

/

2

100%

	2013 7	2014 9	2014 10
100%	1,328.48	6,100.00	6,100.00
	-	359.17%	0.00%

2013 7

2013 1 11

Günther Jans

40%

1	Günther Jans		5,313,920.00	40%
---	--------------	--	--------------	-----

2013 7 26

310115400248195

G nther Jans

G nther Jans

G

nther Jans

2013 7

G nther Jans

G nther Jans

40%

2011 12 31

1,265.22

5%

1,328.48

2014 9

70%

4,270.00

31% 30% 9%

2014 9 11

				%
1			18,910,000.00	31.00
			18,300,000.00	30.00

			5,490,000.00	9.00
--	--	--	--------------	------

3

4

1

1

SFDA

IVD

IVD

2

2001 7 -2002 9	[2001]357	
2002 9 -2007 6	[2002]324	
2007 6	[2007]229	



5

4

6

5

3

276	2000 4 1		
12	2004 7 20		
[2007]239	2007 4 28		100,000
[2007]229	2007 6 1		
[2007]240	2007 6 1		1,000 200
[2007]299	2007 6 1		
	2009 6 15		

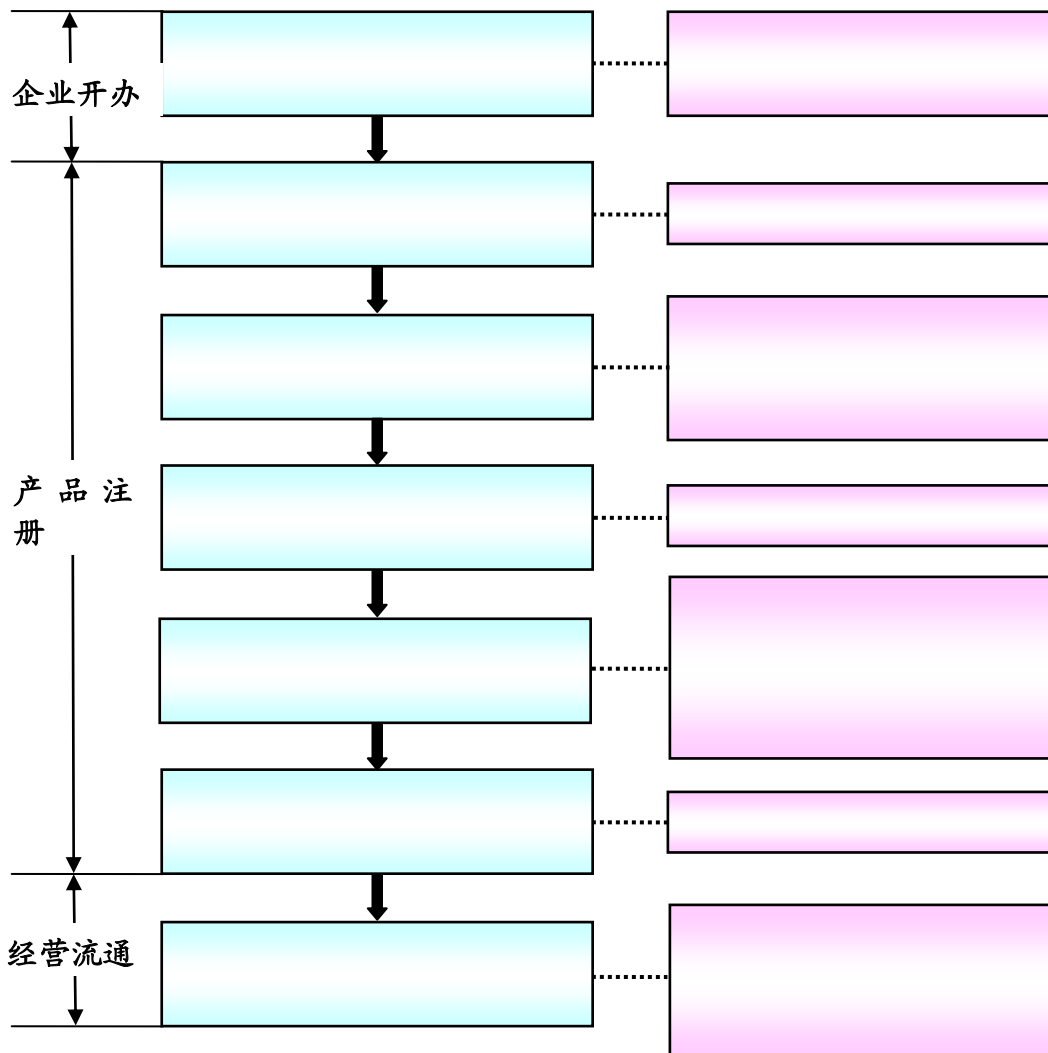

4

2005 12

ELISA

PCR

2006 2



2006-2020 [2005] 044

2006 10

40 15
10

2007 1

2007

2007 4

[2007]23 2010 5,000

2020 2

20

10

2009 6

[2009]45

2010 10

[2010]32

2015

8%

2020

15%

2010 10

863

2011 3

2011

2

130

C-

G

NEFA CysC HCY PALB IgE D-Dimer IgG

LPS



1.				II	6840	
	2017	4	24			
2.					2011	10 28 2016
	11	14				
3.						
4.						
5.						
6.				2017	9	4
1.				II	6840	
		2018	6	27		
2.						
3.						

() (14) S0190

[2015]0710

	2014		2013		2012	
	12,310.70	57.50%	12,303.79	58.00%	10,921.21	59.38%
	8,798.42	41.09%	8,604.21	40.56%	7,157.27	38.92%

	300.90	1.41%	305.28	1.44%	313.31	1.70%
	21,410.02	100.00%	21,213.27	100.00%	18,391.79	100.00%

	2014	2013	2012
	53.77%	51.64%	41.81%
	56.42%	53.01%	47.30%
	29.76%	24.35%	25.71%
	54.52%	51.80%	43.67%

() (14) S0191

[2015]0711

	2014		2013		2012	
	4,601.47	59.75%	4,672.03	62.71%	4,103.75	53.26%
	3,097.20	40.22%	2,768.60	37.16%	3,577.53	46.43%
	2.48	0.03%	9.34	0.13%	23.96	0.31%
	7,701.24	100.00%	7,449.97	100.00%	7,705.24	100.00%

	2014	2013	2012
	3,519.10	7,268.07	7,619.88
	4,182.15	181.90	85.35
	7,701.24	7,449.97	7,705.24

2013 10

2014

2014

HANSS

2013

	2014	2013	2012
	21.12%	18.14%	13.52%
	10.35%	8.78%	14.12%
	-7.90%	-37.04%	15.73%

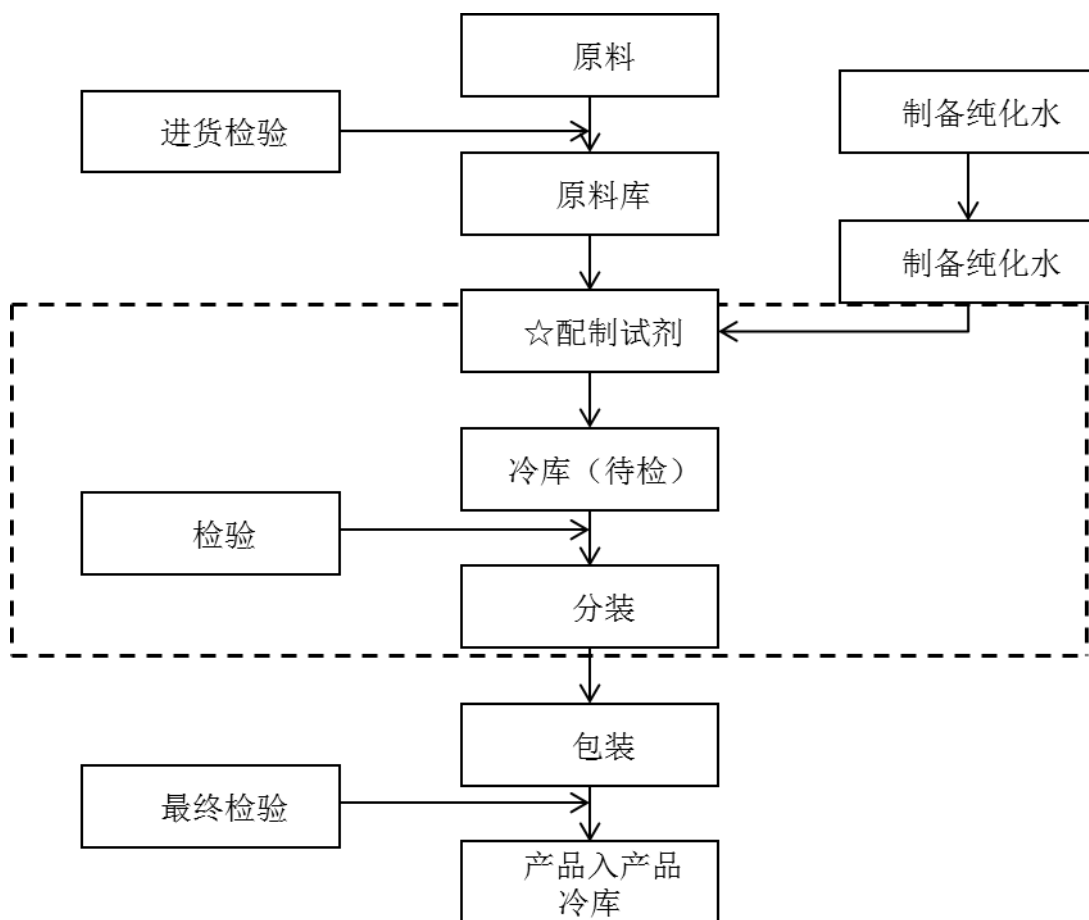

10

10

10

4

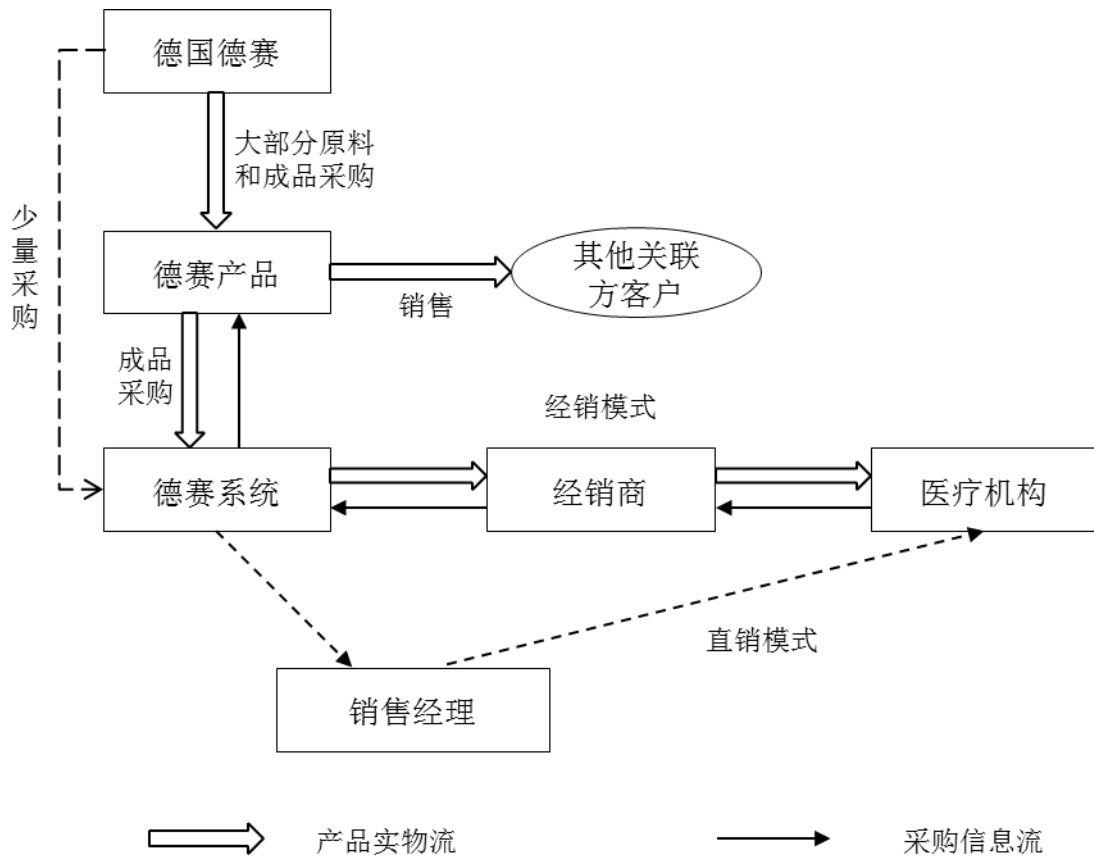

DiaSys

80%

1

80%

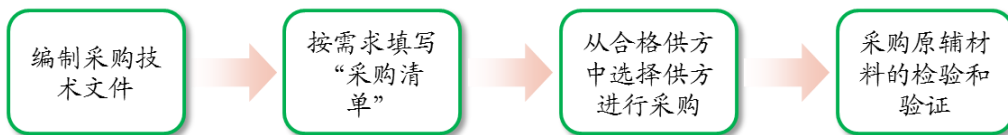

2

3

	2014	2013	2012
	9.01%	6.37%	6.48%
	90.99%	93.63%	93.52%
	100.00%	100.00%	100.00%

4

5

a.

b.

1-3

c.

3

d. ERP

e.

f.

g.

6

5

2014	1		1,664.77	7.77
	2		1,397.22	6.52
	3		1,018.73	4.76
	4		856.89	4.00
	5		770.27	3.60

5,707.88 26.65%

			7,505.85	100.00%
2012	1		7,561.47	98.14%
	2	(MAJA Consulting LTD.)	49.70	0.64%
	3		45.16	0.59%
	4		40.20	0.52%
	5	(PT. Prodia Diagnostic Line)	8.71	0.11%
				7,705.24

80% 20%

22%

3% 3% 3%

2014

5%

24%

13.5%

5%

2013 10

2014

HANSS

2014

2014

HANSS

2013

6

--	--	--	--	--

2014	1		3,732.68	35.28%
	2		2,504.69	23.67%
	3		1,878.32	17.75%
	4		1,646.53	15.56%
	5		538.42	4.89%
				10,300.64
2013	1		7,323.96	73.26%
	2		1,201.70	12.02%
	3		567.01	5.67%
	4		303.58	3.04%
	5		237.61	2.38%
				9,633.86
2012	1		7,561.47	73.43%
	2		1,233.85	11.98%
	3		619.51	6.02%
	4		300.86	2.92%
	5		133.32	1.29%
				9,849.01

80% 20%

30%

30%

30%

5%

2014

2014

2013

2014	1		5,428.57	86.81%
	2		294.85	4.72%
	3	Diazyme	136.70	2.19%
	4		98.60	1.58%
	5		43.20	0.69%
				6,001.92
2013	1		5,401.69	83.99%
	2	Diazyme	448.22	6.97%
	3		329.88	5.13%
	4		105.63	1.64%
	5		66.77	1.04%
				6,352.19
2012	1		5,039.35	79.74%
	2	Diazyme	215.07	3.40%
	3		154.47	2.44%
	4		81.24	1.29%
	5		58.23	0.92%
				5,548.36

80% 20%

22%

3% 3% 3%

2014

5%

24%

13.5%

5%

7

2012 6 30

2014 6 30

90%

1

2

3

4

5



8

1

2

2008 6 11

2009 6 3

2014 9 29
2011 1 2014 9 29

2014 10 10
2011 1 1

2014 10 10

2015 7

2011

1 1

9

1

ISO9001:2008

2

	1
	2

	3
	1 2
	1 2
	1 2 3 4

1 100ml
1

1

a.

pH

b.

pH

c.

1	

2
1
1
2
3
4

3

10

A

B



1 A

2015 1 1

A

A

90,000

2015 1 1

A

A

2015 1 1

A

A

A

2014

A

90,000

2014

21,418.53

A

2 B

B 2012 12 21

2017 12 21

B

B

B

B

B

B

2012 2013

2014

573720.25

8.14

467.01

37820.55

8.24

31.16

160755.90

8.13

130.69

2.54% 0.15% 0.61%

B

B

B

B

B

2017

B

DiaSys

A

B

11

1

90%

28

300

	2014	2013	2012
	9.01%	6.37%	6.48%
	90.99%	93.63%	93.52%
	100.00%	100.00%	100.00%

2014	1		1,664.77	7.77
	2		1,397.22	6.52
	3		1,018.73	4.76
	4		856.89	4.00
	5		770.27	3.60
			5,707.88	26.65%
2013	1		1,345.74	6.34%
	2		1,291.36	6.09%
	3		1,134.37	5.35%
	4		1,111.04	5.24%

	5		928.76	4.38%
			5,811.26	27.40%
2012	1		1,178.60	6.41%
	2		933.14	5.07%
	3		918.29	4.99%
	4		857.36	4.66%
	5		767.24	4.17%
			4,654.64	25.30%

2

1

14

/

2

3

a.

b.

c.

d.

ISO9001 2000 ISO13485 2003

e.

3

f.

g.

h.

90

i. 30

	2012	2013	2014
	0.63%	0.75%	0.67%

a.

b.

1-3

c.

3

d. ERP

e.

f.

g.

12

1 2014

2011 12 6

2014

GR201131000672

2014

GF201431000066

2

15%

2017

25%

7,594.75

75,415.26

10.07%

13

1

					(%)
2014 12 31					
		1,319,789.06	3		6.21
		8,673,772.41	3		40.78
HANSS		11,275,375.80	3		53.01
		21,268,937.27			100.00
2013 12 31					
		3,347,904.88	3		99.80
DIAKON-DS		6,609.05	3		0.20
		3,354,513.93			100.00
2012 12 31					
		8,746,287.69	3		95.93
		371,486.47	3		4.07
		9,117,774.16			100.00

					(%)
2014 12 31					
		4,596,446.88	6		7.36
		4,337,265.08	6		6.94
		4,231,135.25	6		6.77
		4,107,832.66	3		6.58
		3,289,959.07	3		5.27
		20,562,638.94			32.92
2013 12 31					
		5,245,071.86	3		10.29
		5,195,736.01	3		10.20
		4,263,420.17	3		8.37

		3,514,570.98	3	6.90
		3,121,689.83	3	6.13
		21,340,488.85		41.89
2012 12 31				
		4,038,553.87	3	9.39
		3,328,522.82	3	7.74
		3,077,766.71	3	7.16
		2,301,754.82	3	5.35
		2,291,594.00	3	5.33
		15,038,192.22		34.97

90 150

1 2
1-3 3
3 4 ERP
5 6
7

2014 12 31
2015 3 31 126
2014 12 31
2015 3 31 ;

2014 12 31

HANSS

2015 3 31

2014 12 31

2015 3 31

2014 12 31

2015 3 31

2,593,895.05

1,743,370.03

2014 12 31

2015

3 31

2,740,245.94

1,490,889.31

2014 12 31

2015 3 31

2014 12 31

2015 3 31

2

				(%)
2014 12 31				
		28,595.23	3	14.15
-		173,450.87		85.85
		202,046.10		100.00
2013 12 31				
Günther Jans		405,076.84	3	60.84
-		173,450.87	1	26.05
		66,000.00	3	9.91

		21,311.49	3	3.20
		665,839.20		100.00

2012 12 31

-		170,447.59	1	70.92
		35,000.00	3	14.56
		34,887.07	3	14.52
		240,334.66		100.00

1 6 1 1,266.50 1 2 1,736.78
3 170,447.59

				(%)
--	--	--	--	-----

2014 12 31

		16,100,000.00	1	88.69
		300,000.00	3	1.65
		113,308.00	3	0.62
		76,687.00	3	0.42
		65,000.00	3	0.36
		16,654,995.00		91.74

2013 12 31

		8,062,221.00	3	54.26
		5,324,296.93	6	35.83
		357,692.00	1	2.41
		135,810.00	6	0.91
		100,000.00	6	0.67
		13,980,019.93		94.08

2012 12 31

		12,074,134.62	1	67.65
		3,450,000.00	1	19.33
		897,692.00	6	5.03
		176,100.00	6	0.99
		61,840.00	6	0.35
		16,659,766.62		93.35

1 1 3 74,134.62 1
12,000,000.00

2014 12 31 2015 3
31

2014 12 31
,

2014 12 31 16,100,000.00
2015 3 31
9,000,000.00

2014 12 31
2015 3 31
3

2014 12 31			

		159.00	6
		1,500.00	6
		84.00	6
		1,743.00	

2013 12 31

		108,861.39	3
		78,283.93	3
		67,460.00	3
		14,100.00	3
		268,705.32	

2012 12 31

		108,032.04	3
		63,510.00	3
		14,100.00	3
		185,642.04	

--	--	--	--

2014 12 31

		115,456.85	
		29,635.90	
		79,650.00	
		22,000.00	
		20,000.00	
		266,742.75	

2013 12 31

		247,500.00	
		54,135.90	
		29,640.00	

		18,260.00	
		8,910.00	
		358,445.90	
2012 12 31			
		33,000.00	
		30,000.00	
		29,635.90	
		20,300.00	
		20,000.00	
		132,935.90	

2015 3 31

2015 3 31
115,456.85

14

() (14) S0190

[2015]0710

	2014 12 31	2013 12 31	2012 12 31
	154,767.10	154,579.88	483,217.00
	1,173,951.57	1,180,274.69	158,242.32
	16,949,821.82	8,583,015.43	9,028,734.76
	18,278,540.49	9,917,870.00	9,670,194.08

() (14) S0191

[2015]0711

	2014 12 31	2013 12 31	2012 12 31
	2,043,654.89	1,080,095.62	480,590.48
	587,448.65	999,358.09	1,148,097.47
	4,803,943.70	7,076,454.85	6,139,846.63
	1,605,190.81	2,483,991.14	699,305.60
	9,040,238.05	11,639,899.70	8,467,840.18

15

,

	2014	2013	2012
	3	3	3
	8	5	5
	5	5	4
	16	13	12

1

[2015]0710

[2015]0711

2

90%

14

/

3

4

1

a.

100

100

b.

1

2

1

1

2

3	3		0%	0%
4	6	6	25%	25%
7	12	12	50%	50%
1			100%	100%

c.

a.

	300	300

b.

1	
2	

1	(1)	5%
1-2		10%

2-3	50%	50%
3	100%	100%

c.

2

3

		%	%
	20	5	4.75
	10	5	9.5
	3	5	31.67
	4	5	23.75
	5	5	19

		%	%
	20-30	0	3.33-5.00
	3-8	2-10	11.25-32.67

	4-8	5-10	11.25-23.75
	5-6	2-10	15.00-19.60

2011

1 1 2014 10 20

2011 1 1

2014 10 20

2011 1 1 2014 8 31

2011 1 1 2014 8 31

2011 1 2014

9 29

2011 1 2014 10 14



						2011	1	1
2014	10	14						
						2011	1	1
2014	9	9						
						2011	1	
1	2014	10	27					
						2011	1	
1	2014	10	27					
2011	1	1	2014	8	31			

2014 9 11

49,247.82

70%

25% 24% 13.5% 7.5%

2014 9 11

4,270

70%

31% 30% 9%

2014 12 31

70%

45%

39%



2014 10 15

109

2014

11 24

45%

39%

2014 8 31

100%

75,415.26

II

2014 6 30

5,000

2014 6 30

5,000

45%

31,680

100%

6,105.12

39%

2,379

45%		16,896.00	6,177,697
		9,504.00	3,474,954
		5,280.00	1,930,530
		31,680.00	11,583,181
39%		1,830.00	669,104
		549.00	200,731
		2,379.00	869,835
		34,059.00	12,453,016

70%

70%

45%

39%

34,059

1

A

1.00

2

3

20 90% 60 120

=

/

20

27.3443 /

27.35 /

90%

4

$$= \quad 45\% \quad + \quad 39\%$$

$$+ \quad =$$

1		6,846,801
2		3,675,685
3		1,930,530
	-	12,453,016

5

6

7

30%
22% 5% 3%
30%

8%

2014

[2015]1550

	2014	2014	%
	161,616.86	191,663.39	18.59%
	96,451.11	134,221.47	39.16%
	53,697.08	69,509.49	29.45%
	16,779.53	21,474.95	27.98%
	12,828.13	16,539.50	28.93%
/	0.84	0.97	15.48%
/	0.81	0.94	16.05%

2014 12 31

157,267,000

12,453,016

	56,448,000	35.89%	0	56,448,000	33.26%
	35,712,000	22.71%	0	35,712,000	21.04%
	0	0.00%	6,846,801	6,846,801	4.03%

	0	0.00%	3,675,685	3,675,685	2.17%
	0	0.00%	1,930,530	1,930,530	1.14%
	65,107,000	41.40%	0	65,107,000	38.36%
	157,267,000	100.00%	12,453,016	169,720,016	100.00%

2014 12 31

54.30%

4.03%

2.17%

1.14%

58.60%

54.30%



45%

100%

2014	1106		2014	8	31
		100%	75,415.26		
13,006.74		62,408.52	479.82%		

1020008

0100001001

2014 8 31

1

1

2



3

2

1

2

3

4

5

6

7

8

9

10

11

1

	19,148.89	24,066.64	4,917.75
25.68%	6,142.15	6,142.15	
	13,006.74	17,924.49	4,917.75

37.81%

2

					%
		B	C	D=C-B	E=D/B×100%
1		15,663.94	16,089.84	425.90	2.72
2		3,484.95	7,976.80	4,491.85	128.89
3		-	-	-	
4		-	-	-	
5		2,898.57	6,522.65	3,624.08	125.03
6		71.48	65.23	-6.25	-8.74
7		20.70	894.73	874.03	4,222.37
8		-	-	-	
9		-	-	-	
10		19,148.89	24,066.64	4,917.75	25.68
11		6,139.15	6,139.15	-	-
12		3.00	3.00	-	-
13		6,142.15	6,142.15	-	-
14		13,006.74	17,924.49	4,917.75	37.81

3

4,259,014.22 15,822,229.53 20,081,243.75
26.92%

-

-

-

DCF

2014 8 31

13,006.74

() 75,415.26

62,408.52

479.82%

1

$$E = B - D$$

E ()

B

$$B = P + C$$

P

$$P = \sum_{i=1}^n \frac{R_i}{(1+r)^i} + \frac{R_{n+1}}{r(1+r)^n}$$



2014

2014

1

95%

2013

73.1

4.2

6.1%

/

1.5

30

2

3

4

5

/

respons@920

respons@910

InnovaStar®

2015

respons@940

2014

2015

2016

	2014 9-12	2015	2016	2017	2018	2019
	5,297.33	14,452.20	15,536.12	16,701.33	17,953.93	19,300.47
	2,582.77	6,883.69	7,399.96	7,954.96	8,551.58	9,192.95
	3,767.32	11,189.33	13,091.52	15,317.08	17,920.98	20,967.55
	1,802.46	5,136.27	6,009.44	7,031.04	8,226.32	9,624.79
	120.49	327.16	327.16	327.16	327.16	327.16
	119.06	256.66	256.66	256.66	256.66	256.66
	-	500.00	1,000.00	2,000.00	3,000.00	3,000.00
	-	385.00	770.00	1,540.00	2,310.00	2,310.00
	9,185.15	26,468.70	29,954.80	34,345.57	39,202.07	43,595.18
	4,504.29	12,661.61	14,436.06	16,782.66	19,344.56	21,384.40

2

/	2014 9-12	2015	2016	2017	2018	2019
	9,185.15	26,468.70	29,954.80	34,345.57	39,202.07	43,595.18
	81.58	241.47	271.13	306.26	345.78	387.09
/	0.0089	0.0091	0.0091	0.0089	0.0088	0.0089

3

a.

	2014 9-12	2015	2016	2017	2018	2019
	221.27	614.20	695.09	796.98	909.67	1,011.61
	251.61	600.06	679.09	778.64	888.74	988.33
	83.68	148.14	162.95	179.25	197.18	216.89
	366.48	670.21	758.48	869.66	992.63	1,103.87
	50.83	118.89	134.55	154.27	176.08	195.81
	93.31	265.43	300.39	344.42	393.12	437.18

b.

	2014 9-12	2015	2016	2017	2018	2019
	849.75	2,206.39	2,427.02	2,669.73	2,936.70	3,230.37
	69.73	211.86	211.86	211.86	211.86	211.86

	25.28	85.86	85.86	85.86	85.86	85.86
	87.00	306.71	347.11	397.99	454.26	505.17
	51.53	157.98	178.78	204.99	233.97	260.19
	436.00	756.63	802.71	928.22	1,067.05	1,157.63

4

-

-

5

2011 12 6

GR201131000672

15%

2014

15%

6

a.

b.

20.70

100.32

7

= + +

a.

2014

b.

c.

= -

= + + -

= /

= /

= /

/	2014	2015	2016	2017	2018	2019	2020
	1,376.49	1,557.83	1,761.64	2,029.94	2,323.83	2,568.73	2,568.73
	1,896.46	2,173.04	2,477.58	2,880.31	3,319.99	3,670.08	3,670.08
	6,226.27	7,062.53	7,992.71	9,164.28	10,460.12	11,632.31	11,632.31
	3,058.85	3,504.95	3,996.15	4,645.73	5,354.91	5,919.57	5,919.57
	6,440.37	7,288.44	8,235.77	9,428.80	10,749.04	11,951.55	11,951.55
	627.79	848.07	947.33	1,193.03	1,320.24	1,202.52	-

8

	2014 9-12	2015	2016	2017	2018	2019	2020
	9,185.15	26,468.70	29,954.80	34,345.57	39,202.07	43,595.18	43,595.18
	4,504.29	12,661.61	14,436.06	16,782.66	19,344.56	21,384.40	21,384.40
	81.58	241.47	271.13	306.26	345.78	387.09	387.09
	1,067.17	2,416.93	2,730.56	3,123.22	3,557.42	3,953.70	3,953.70
	1,519.29	3,725.42	4,053.35	4,498.65	4,989.71	5,451.09	5,451.09
	-	-	-	-	-	-	-

	2,012.81	7,423.26	8,463.70	9,634.79	10,964.60	12,418.90	12,418.90
	-	-	-	-	-	-	-
	-	-	-	-	-	-	-
	2,012.81	7,423.26	8,463.70	9,634.79	10,964.60	12,418.90	12,418.90
	307.23	1,121.06	1,270.62	1,446.25	1,645.32	1,860.55	1,860.55
	1,705.59	6,302.20	7,193.08	8,188.53	9,319.28	10,558.35	10,558.35
	87.41	265.60	265.60	265.60	265.60	265.60	265.60
	25.28	85.86	85.86	85.86	85.86	85.86	85.86
	-	-	-	-	-	-	-
	112.69	351.46	351.46	351.46	351.46	351.46	351.46
	627.79	848.07	947.33	1,193.03	1,320.24	1,202.52	-
	388.27	-	-	-	-	-	-
	689.53	5,454.13	6,245.75	6,995.50	7,999.04	9,355.83	10,558.35

4

WACC

r

$$r = r_d \times w_d + r_e \times w_e$$

Wd

$$w_d = \frac{D}{(E + D)}$$

We

$$w_e = \frac{E}{(E + D)}$$

rd

re

CAPM

re

$$r_e = r_f + \beta_e \times (r_m - r_f) + \varepsilon$$

r_f

r_m

e

$$\beta_e = \beta_u \times (1 + (1-t) \times \frac{D}{E})$$

u

$$\beta_u = \frac{\beta_t}{1 + (1-t) \frac{D_i}{E_i}}$$

t

$$\beta_t = 34\%K + 66\%\beta_x$$

K

K=1

x

D_i E_i

rf

rf

rf=3.94%

rm

1992 5 21

2013 12 31

rm=10.19%

β_e

2009 9 2014 8 250

$$\beta_t = 34\%K + 66\%\beta_x$$

$$\beta_u = \frac{\beta_i}{1 + (1-t) \frac{D_i}{E_i}}$$

$$\beta_e = \beta_u \times \left(1 + (1-t) \times \frac{D}{E}\right)$$

0.8220

re

$$r_e = r_f + \beta_e \times (r_m - r_f) + \varepsilon$$

re

$$re = 0.0394 + 0.8220 \times (0.1019 - 0.0394) + 0.0300 = 0.1208$$

15%

$$w_d = \frac{D}{(E+D)} \quad w_e = \frac{E}{(E+D)}$$

Wd=0

We=1

r

$$r = r_d \times w_d + r_e \times w_e = 0.1208$$

5

3

$$P = \sum_{i=1}^n \frac{R_i}{(1+r)^i} + \frac{R_{n+1}}{r(1+r)^n}$$

72,484.53

6

()

1		C1	
a.			II
6,004.51	2014 6 30	5,000	2014
6 30		5,000	
		4,822.23	
b.			
		1,200.00	
c.			471.50
d.			
	400.00		
C1=2,750.73 ()			
		6,004.51	
		1,200	4,822.23

1,200

2,500

2014 10 24

Letter of Cancellation

2,500

2014 10 24

2

C2

180.00

$C_2 = 180.00$

$$C = C_1 + C_2$$

:

$$C = C_1 + C_2 = 2,930.73 (\quad)$$

7

$$P = 72,484.53$$

$$C = 2,930.7$$

$$B = P + C$$

$$B=P+C= 75,415.26 (\quad)$$

$$B= 75,415.26$$

$$D=0$$

$$E=B-D= 75,415.26 (\quad)$$

1

1

45%

/

/3

/ 1

2

,

,

,

3

93%

2015

19,222.22

2015

72.62%

4

respons@920

respons@910

respons@940

InnovaStar®

a.respons@

respons@

respons@920

respons@910

respons@940

respons@

respons@

A

G

M

C3

C4

O

C

MB

respons@

I

II



III

8

1 6 2

1

2-6

7

8

IV

30

200

/

ISE

360

/

b.InnovaStar®

InnovaStar®

POCT

InnovaStar®

A1c

C

InnovaStar®

I

A1c

POCT

II

IFCC

HbA1c

InnovaStar®

HbA1c

IFCC

HbA1c

		30mmol HbA1c/mol Hb		1.8%	60mmol
HbA1c/mol Hb		1.0%	90mmol HbA1c/mol Hb		
0.3%	CV	1.74%	r	0.9974	
		HbA1c			

III

C- D-

respons® InnovaStar®

2010 2012

23

35

100 200 400 /

respons®920

		13.85%		4.48%	7.50%	7.50%
	3,577.53	2,768.60	2,211.15	3,307.33	3,869.58	4,527.40
		-22.61%		19.46%	17.00%	17.00%
	23.96	65.23	48.67	65.23	65.23	65.23

2012 2013

7,705.24

7,505.86

2012 2013

18,391.79

21,213.27

15.34%

2015

2019

11%-12%

2015 2019

11%-12%

2

	2012	2013	2014 1-8	2014	2015	2016
	18,391.79	21,213.27	14,149.46	23,334.60	26,468.70	29,954.80
	43.7%	51.8%	53.7%	52.6%	52.2%	51.8%
	10,921.21	12,303.79	8,146.58	13,443.91	14,452.20	15,536.12
	41.8%	51.6%	53.1%	52.4%	52.4%	52.4%

	7,157.27	8,604.21	5,796.22	9,563.53	11,189.33	13,091.52
	47.3%	53.0%	55.2%	54.0%	54.1%	54.1%
	25.7%	24.4%	38.3%	24.6%	21.6%	21.6%
					23.0%	23.0%

98%

2013 2014 1-8

	2012	2013	2014 1-8	2014	2015	2016
	7,705.24	7,505.86	5,110.39	8,253.80	9,182.14	10,233.52
	13.8%	14.7%	14.0%	14.3%	14.1%	13.9%
	4,103.75	4,672.03	2,850.57	4,881.24	5,247.34	5,640.89
	13.5%	18.1%	17.7%	17.7%	17.7%	17.7%
	3,577.53	2,768.60	2,211.15	3,307.33	3,869.58	4,527.40
	14.1%	8.8%	9.1%	9.1%	9.1%	9.1%
	15.7%	14.9%	17.6%	14.9%	14.9%	14.9%

98%

14%

2014 1-8

2014

2013

2014

3

2012 2013 2014 1-8
 0.0924 0.0903 0.0755
 0.0907- 0.0915 2012 2013

	2012	2013	2014 1-8	2014	2015	2016
	1,698.81	1,914.89	1,067.65	2,134.82	2,416.93	2,730.56
	0.0924	0.0903	0.0755	0.0915	0.0913	0.0912

4

0.1243 0.2016 0.1349
 0.1250- 0.1469 2012 2013

	2012	2013	2014 1-8	2014	2015	2016
	2,285.51	4,277.27	1,908.38	3,427.67	3,725.42	4,053.35
	0.1243	0.2016	0.1349	0.1469	0.1407	0.1353

2013

1200

5.66%

2014 10

0.0420 0.0673 0.0834
 0.0398 - 0.0675 2012 2013

	2012	2013	2014 1-8	2014	2015	2016
	323.36	504.86	426.05	557.39	489.14	507.77
	0.0420	0.0673	0.0834	0.0675	0.0533	0.0496

2014 10

2013 2014 1-8

1.56% 1.72%

5

1

Rm

1992 5 21

2013 12

300273.SZ		14.72
300289.SZ		10.35
300298.SZ		17.81
300318.SZ		6.76
600055.SH		4.13
600196.SH		11.61
600587.SH		8.26
		11.40

wind

2013

12.08%

11.40%

6

5% 10%

4.44% 8.87%

5% 10%

4.44% 8.87%

10%	82,107.07	8.87%
5%	78,761.17	4.44%
-5%	72,069.36	-4.44%
-10%	68,723.45	-8.87%

5% 10%

2.94% 5.88%

5% 10%

2.94% 5.88%

--	--	--

10%	6,463.95	5.88%
5%	6,284.54	2.94%
-5%	5,925.71	-2.94%
-10%	5,746.29	-5.88%

2014

1

75,415.26

57,490.77

320.74%

1

()

2

()

2

1

2008-2012

16%

2010

	20.7	(136.8)			5.7	
	(37.8)		15.0	(99)
	McEvoy&Farmer							
	/		1.5			25	30	
						15%	20%	
		1					95%	
2013					73.1		4.2	
	6.1%							
				/		1.5		
	30		2					
				3				
							4	
						5		
							/	
	2							
					1991			
						CE		
							DiaSys	
			50		74%		2009	
		10%					2013	

13,006.74	62,408.52	75,415.26	479.82%
	[2015]0710		2014

	2014	2014	
	21,418.53	23,334.60	91.79%
	9,744.22	11,050.06	88.18%
	173.99	203.11	85.66%
	1,777.09	2,134.82	83.24%
	2,804.69	3,427.67	81.82%
	-7.12	-27.97	25.44%
	57.78	96.25	60.03%
	6,867.87	6,450.66	106.47%
	303.93	166.37	182.69%
	4.52	2.06	218.95%
	7,167.29	6,614.96	108.35%
	1,224.96	1,183.22	103.53%
	5,942.33	5,431.74	109.40%

2014 1-12 21,418.53
 2014 91.79% 5,942.33 2014
 109.40%

2014

2014

2014

	2012	2013	2014	2014
	3,439.44	3,792.77	3,370.21	422.56
	1,011.06	1,111.04	856.89	254.15
	1,160.73	1,480.29	1,238.41	241.88

2014

1

54.51% 17.33%

52.65%

14.26% 2

2014

	2012	2013	2014	2014	
1	606.82	958.93	1,480.07	54.35%	75%
2	112.51	148.78	346.87	133.14%	71%
3	1,142.01	1,657.67	1,826.84	10.21%	58%

4	210.15	248.91	355.49	42.82%	69%
5	0	0	51.19	-	79%

2014 1-8

2014

39%

100%

2014 1107

2014 8 31

100%

6,105.12

1,864.70

4,240.42

227.40%

1020008

0100001001

2014 8 31

1

1

2



3

2

1

2

3

4

5

6

7

8

9

10

1

	4,312.17	4,456.83	144.66
3.35%	2,447.47	2,447.47	
	1,864.70	2,009.36	144.66
7.76%			

2

		B	C	D=C-B	% E=D/B×100%
1		4,113.88	4,166.56	52.68	1.28
2		198.29	290.27	91.98	46.39
3		-	-	-	-
4		192.53	284.51	91.98	47.77
5		-	-	-	-
6		4,312.17	4,456.83	144.66	3.35
7		2,447.47	2,447.47	-	-
8		-	-	-	-
9		2,447.47	2,447.47	-	-
10		1,864.70	2,009.36	144.66	7.76

DCF

2014 8 31 100% 1,864.70
() 6,105.12 4,240.42
227.40%

1

$$E = B - D$$

E ()

B

$$B = P + C$$



2014

2014

1

95%

2013

73.1

4.2

6.1%

/

1.5

30

2

3

4

5

/

respons@920

respons@910

InnovaStar®

2015

respons@940

2014

2015

2016

	2014 9-12	2015	2016	2017	2018	2019
	2,030.67	5,247.34	5,640.89	6,063.96	6,518.75	7,007.66
	1,670.44	4,316.48	4,640.22	4,988.23	5,362.35	5,764.53
	1,096.18	3,869.58	4,527.40	5,297.06	6,197.56	7,251.15
	996.38	3,517.29	4,115.23	4,814.82	5,633.34	6,591.01
	16.56	65.23	65.23	65.23	65.23	65.23
	15.43	55.52	55.52	55.52	55.52	55.52
	3,143.41	9,182.14	10,233.52	11,426.25	12,781.55	14,324.04
	2,682.26	7,889.29	8,810.97	9,858.58	11,051.21	12,411.06

2

<i>/</i>	2014 9-12	2015	2016	2017	2018	2019
	3,143.41	9,182.14	10,233.52	11,426.25	12,781.55	14,324.04
	1.44	3.61	3.82	4.03	4.26	4.48
<i>/</i>	0.0005	0.0004	0.0004	0.0004	0.0003	0.0003

3

	2014 9-12	2015	2016	2017	2018	2019
	68.04	244.63	256.86	269.71	283.19	297.35
	15.36	46.07	46.07	46.07	46.07	46.07
	23.02	70.41	70.41	70.41	70.41	70.41
	-		-	-	-	-
	24.92	128.03	134.43	141.15		

6

$$= \quad + \quad +$$

a.

b.

$$= \quad -$$

$$= \quad + \quad + \quad -$$

$$= \quad /$$

$$= \quad /$$

$$= \quad /$$

/	2014	2015	2016	2017	2018	2019	2020
	476.41	523.15	582.38	649.59	726.00	813.01	813.01
	1,212.22	1,351.35	1,509.22	1,688.66	1,892.95	2,125.87	2,125.87

	1,839.75	2,046.67	2,281.02	2,546.88	2,848.97	3,192.78	3,192.78
	871.63	971.67	1,085.18	1,214.21	1,361.10	1,528.58	1,528.58
	2,656.75	2,949.51	3,287.44	3,670.92	4,106.82	4,603.08	4,603.08
	48.69	292.76	337.93	383.49	435.90	496.26	-

7

	2014 9-12	2015	2016	2017	2018	2019	2020
	3,143.41	9,182.14	10,233.52	11,426.25	12,781.55	14,324.04	14,324.04
	2,682.26	7,889.29	8,810.97	9,858.58	11,051.21	12,411.06	12,411.06
	1.44	3.61	3.82	4.03	4.26	4.48	4.48
	-	-	-	-	-	-	-
	131.34	489.14	507.77	527.34	547.88	569.45	569.45
	-	-	-	-	-	-	-
	328.38	800.10	910.96	1,036.30	1,178.19	1,339.04	1,339.04
	328.38	800.10	910.96	1,036.30	1,178.19	1,339.04	1,339.04
	82.09	200.03	227.74	259.07	294.55	334.76	334.76
	246.28	600.08	683.22	777.22	883.64	1,004.28	1,004.28
	24.73	74.18	74.18	74.18	74.18	74.18	74.18
	-	-	-	-	-	-	-
	-	-	-	-	-	-	-
	24.73	74.18	74.18	74.18	74.18	74.18	74.18
	48.69	292.76	337.93	383.49	435.90	496.26	-
	-	-	-	-	-	-	-
	197.59	307.32	345.29	393.74	447.75	508.02	1,004.28

4

WACC

r

$$r = r_d \times w_d + r_e \times w_e$$

Wd

$$w_d = \frac{D}{(E + D)}$$

We

$$w_e = \frac{E}{(E + D)}$$

rd

re

CAPM

re

$$r_e = r_f + \beta_e \times (r_m - r_f) + \varepsilon$$

r_f

r_m

e

$$\beta_e = \beta_u \times \left(1 + (1-t) \times \frac{D}{E}\right)$$

u

$$\beta_u = \frac{\beta_t}{1 + (1-t) \frac{D_i}{E_i}}$$

t

$$\beta_t = 34\%K + 66\%\beta_x$$

K

K=1

x

D_i E_i

rf

rf

rf=3.94%

rm

1992 5 21

2013 12 31

rm=10.19%

β_e

2009 9 2014 8 250

$$\beta_t = 34\%K + 66\%\beta_x$$

$$\beta_u = \frac{\beta_t}{1 + (1-t)\frac{D_i}{E_i}}$$

$$\beta_e = \beta_u \times (1 + (1-t) \times \frac{D}{E})$$

re

$$r_e = r_f + \beta_e \times (r_m - r_f) + \varepsilon$$

re

$$re=0.0394+ 0.8220 \times (0.1019-0.0394)+0.0300=0.1208$$

25%

$$w_d = \frac{D}{(E+D)} \quad w_e = \frac{E}{(E+D)}$$

Wd=0

We=1

r

$$r=rd \times wd+re \times we=0.1208$$

5

3

$$P = \sum_{i=1}^n \frac{R_i}{(1+r)^i} + \frac{R_{n+1}}{r(1+r)^n}$$

6,064.61

6

$$C_2=0$$

$$C = C_1 + C_2 = 40.51 (\quad)$$

7

$$P=6,064.61$$

$$I=0$$

$$C = 40.51$$

$$B = P + I + C = 6,105.12 (\quad)$$

$$B = 6,105.12$$

$$D = 0$$

$$E = B - D$$

$$E = B - D = 6,105.12 (\quad)$$

$$45\% \quad /$$

1

$$6,105.12$$

$$4,095.76$$

$$203.83\%$$

1
()

2
()

2

1

2008-2012

16% 2010

20.7 (136.8) 5.7
(37.8) 15.0 (99)

McEvoy&Farmer

/ 1.5 25 30
15% 20%
1 95%

2013 73.1 4.2
6.1%

30 2 / 1.5
3 4
5
/

2

1991

CE

DiaSys

74% 2009 50
2013 10%

1,864.70 4,240.42 6,105.12
227.40%

[2015]0711

2014

	2014	2014	
	7,878.67	8,253.80	95.46%
	6,513.25	7,077.09	92.03%
	2.74	2.12	129.15%
	519.92	557.39	93.28%
	237.34	87.36	271.69%
	605.42	529.85	114.26%

	30.73	1.93	1596.07%
	0.06	0.06	100.00%
	636.09	531.72	119.63%
	160.53	134.99	118.92%
	475.56	396.73	119.87%

2014 1-12

7,878.67

2014 95.46% 475.56 2014
119.87%

1

45%

31,680

2013

4,148.03

2014

5,513.33

	448.15	475.56
	1,864.70	
39%	2,379.00	
	13.61	12.83
	3.27	

$$= \frac{39\%}{39\%} / \frac{*39\%}{*39\%}$$

3

2014 8 31

		PE	PB
002022.SZ		39.35	10.43
002030.SZ		66.79	12.24
300289.SZ		36.35	4.75
300298.SZ		48.14	8.47
300318.SZ		64.59	4.98
600196.SH		23.02	2.74
		46.37	7.27

Wind
P/E= 2014 8 31 / 2013
P/B= 2014 8 31 / 2014 6 30

2014 8 31 46.37
7.27 2014
11.85 12.83 2014 8 31
5.41 3.27

	2014	0.84	2014	12	31	
6.13		27.35	/			32.56
	4.46			2014		11.85
12.83						

/

1

2

3

4

1

() (14) S0190

[2015]0710

2013

2014

/	2014	2013
	214,185,274.22	212,132,748.14
	97,442,185.01	102,246,904.31
	54.51%	51.80%
	59,423,340.01	41,480,322.08
	27.74%	19.55%

() (14) S0191

[2015]0711

2013

2014

/	2014	2013
	78,786,715.76	75,058,588.17
	65,132,454.59	64,057,046.83
	17.33%	14.66%
	4,755,607.82	4,481,499.80
	6.04%	5.97%

2014 1106

100%

/	2014 9-12	2015	2016	2017	2018	2019
	9,185.15	26,468.70	29,954.80	34,345.57	39,202.07	43,595.18
	4,504.29	12,661.61	14,436.06	16,782.66	19,344.56	21,384.40

	50.96%	52.16%	51.81%	51.14%	50.65%	50.95%
	1,705.59	6,302.20	7,193.08	8,188.53	9,319.28	10,558.35
	18.57%	23.81%	24.01%	23.84%	23.77%	24.22%

2014 1107

100%

/	2014 9-12	2015	2016	2017	2018	2019
	3,143.41	9,182.14	10,233.52	11,426.25	12,781.55	14,324.04
	2,682.26	7,889.29	8,810.97	9,858.58	11,051.21	12,411.06
	14.67%	14.08%	13.90%	13.72%	13.54%	13.36%
	246.28	600.08	683.22	777.22	883.64	1,004.28
	7.83%	6.54%	6.68%	6.80%	6.91%	7.01%

1

/	2014	2015	2016	2017	2018	2019	2020
	23,334.60	26,468.70	29,954.80	34,345.57	39,202.07	43,595.18	43,595.18
	-	13.43%	13.17%	14.66%	14.14%	11.21%	0.00%
	8,253.80	9,182.14	10,233.52	11,426.25	12,781.55	14,324.04	14,324.04
	-	11.25%	11.45%	11.66%	11.86%	12.07%	0.00%

2012 2013 18,391.79 21,213.27

15.34% 2014 1-12

21,418.53 2014 91.79% 5,942.33

2014 109.40% 2014 1-12

7,878.67 2014

95.46% 475.56 2014 119.87%

2014

2014

2014

	2012	2013	2014	2014
	3,439.44	3,792.77	3,370.21	422.56
	1,011.06	1,111.04	856.89	254.15
	1,160.73	1,480.29	1,238.41	241.88

2014

1

54.51%

17.33%

52.65% 14.26% 2

2014

	2012	2013	2014	2014	
1	606.82	958.93	1,480.07	54.35%	75%
2	112.51	148.78	346.87	133.14%	71%
3	1,142.01	1,657.67	1,826.84	10.21%	58%
4	210.15	248.91	355.49	42.82%	69%
5	0	0	51.19	-	79%

2014 1-8

				2014
			2015	2019
11%-15%				
2015	2019			11%-15%
2				
50%		2014	54.51%	
		14%	2014	17.33%
3				
24%		2014	27.74%	
		7%	2014	6.04%
2				
			2012	5 10
				2012

2012 12

2011 3

2011

3

1991

CE

1997

DiaSys

50

74%

2009

10%

2013

2014

2.14

5,942.33

7,878.67

475.56

2013

2.12

4,148

7,506

448

1

Kalorama

2007

10.15

2012

21.75

16.47%

6.07%

2012

3.86%

2010

184.5

2012

221

9%

2010

137

2012

150

5%

2012

29

8,000

6%

15%~20%

2015

2

2012 5 10

2012

2012 12

3

DiaSys

2014 9 11

DiaSys



1

4.44% 8.87%

5% 10%

4.44% 8.87%

5% 10%

10%	82,107.07	8.87%
5%	78,761.17	4.44%
-5%	72,069.36	-4.44%
-10%	68,723.45	-8.87%

2.94% 5.88%

5% 10%

2.94% 5.88%

5% 10%

10%	6,463.95	5.88%
5%	6,284.54	2.94%
-5%	5,925.71	-2.94%
-10%	5,746.29	-5.88%

2

-10% 10%

10%	89,265.90	0.18	7,238.52	0.19
5%	82,340.58	0.09	6,671.82	0.09
0%	75,415.26	0.00	6,105.12	0.00
-5%	68,489.94	-0.09	5,538.42	-0.09
-10%	61,564.62	-0.18	4,971.73	-0.19

1

2

3



50
10%

74%

2009

300

4

IVD

5

6

2014 8 31

		PE	PB
002022.SZ		39.35	10.43
002030.SZ		66.79	12.24
300289.SZ		36.35	4.75
300298.SZ		48.14	8.47
300318.SZ		64.59	4.98
600196.SH		23.02	2.74
		46.37	7.27

Wind

P/E= 2014 8 31 / 2013

P/B= 2014 8 31 / 2014 6 30

2014 8 31 46.37

7.27 16.97

13.09 13.61 16.17

2014 8 31

5.41

3.27

100%

100%

2014 8 31

75,415.26

2014 6 30

6 30

2014 8 31

6,105.12

2,379

2014 1106

100%

II

5,000

2014

5,000

45%

31,680

2014 1107

100%

39%

1

2

3

2014 9 11

2014 10 16

2014 11 6

2014 11 6

1

2014 8 31

100%

75,415.26

II

2014

6 30

5,000

2014 6 30

5,000

45%

31,680

100%

6,105.12

39%

2,379

2

		16,896.00	6,177,697
45%		9,504.00	3,474,954
		5,280.00	1,930,530

30

2014 6 30

5

1

2

3

6

1

2

3

4

1

2

3

4

5

2014 11 6
2014 10 31

2014 11 24

(2014)

1

2014 2015 2016 2017

2

5,516 6,342 6,977 7,674
2014 ~2017

3

1

2

=

70%

2014

9 11

20%

10,703.56

3

4

1

“

”

25%

31%

1

2

3

5%

4

50

5

6

7

2015 1 15



2

7

5

3

“

”

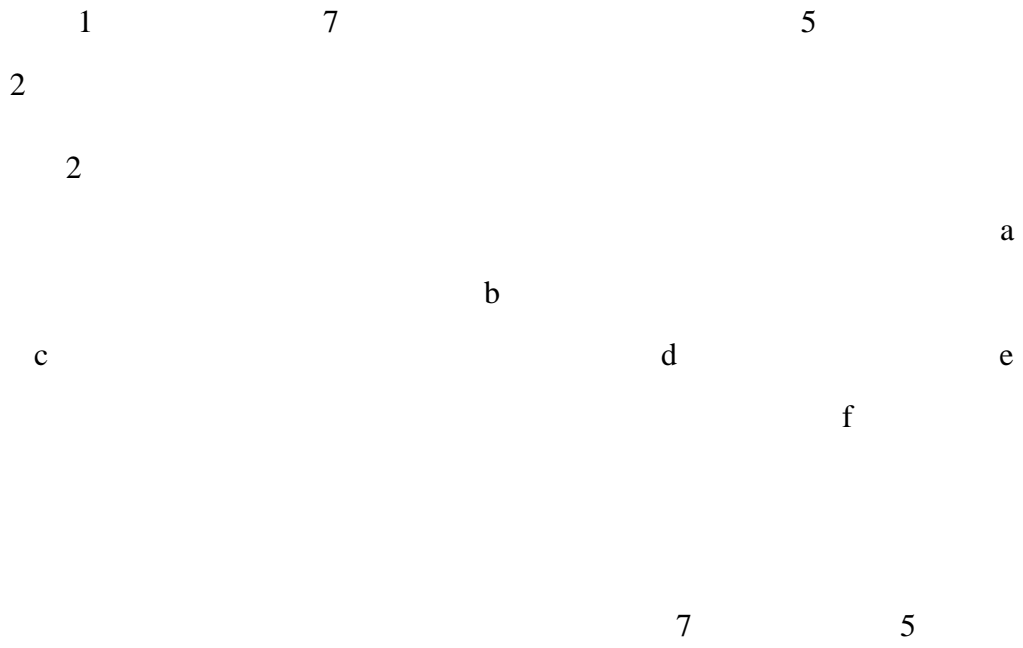

1

2

5

6

;

2014 6 30

2014 9

DiaSys

2014 9 11

1

1 2014 9 11

A B

2015 1 1 A

A A

B B 2012 12

21 2017 12 21

B B

B B

2

3

2

1

2



3

2012 6 30 2014 6 30

90%

4

5

10

10

6

6

3

1

2 2012
3 19 LICENCE AND CO-OPERATION AGREEMENT A
DiaSys

3

4

DiaSys

4

1

DiaSys



5

5

1

2

6

1

2

7

1

2

3

1

2

3

4

1

2

2014 12 31

DiaSys

8

1

2

30

1

45%

39%

2010 10

863

2013 2

2011

2

2009 6 3

2008 6 11

2015 7

2015 7

2014 9 29

2011 1 2014 9 29



			2014	10	10			
						2011	1	1
2014	10	10						
								2011
1	1							
			588	1-28		222	2-21	
9								

	12,453,016	
157,267,000		169,720,016
		25%

1

2014	8	31		100%	75,415.26		
			2014	8	31	13,006.74	62,408.52
						479.82%	
							II
			2014	6	30	5,000	
2014	6	30					
						5,000	
						45%	31,680
2014	8	31		100%	6,105.12		
			2014	8	31	1,864.70	4,240.42
						227.40%	39%
						2,379	

2

	90%		
20	60	120	



=

/

20

27.3443 /

27.35 /

90%

45%

39%



2

3

4

			20%		
		2014			
12,828.13			5,942.23		475.56
				2014 ~2017	
			5,516	6,342	
6,977	7,674				





20%

2014

12,828.13

5,942.23

475.56

2014 ~2017

5,516

6,342

6,977

7,674

1

70%

35.89%

100%

58.60%

2

70%

70%

5%

3

2014

[2015]0706



39%

45%

1

2

3

4





	11,434.87	7.08%	990.44	0.80%
	33,409.67	20.67%	13,346.44	10.73%
	431.73	0.27%	1,481.23	1.19%
	923.55	0.57%	128.87	0.10%
	9,476.09	5.86%	4,630.11	3.72%
	237.59	0.15%	341.30	0.27%
	66,422.56	41.10%	53,695.37	43.16%
	68,672.45	42.49%	65,831.08	52.92%
	541.15	0.33%	1,988.06	1.60%
	4,515.39	2.79%	2,624.69	2.11%
	1,096.23	0.68%	259.18	0.21%
	95,194.30	58.90%	70,703.03	56.84%
	161,616.86	100.00%	124,398.40	100.00%

2014 12 31

161,616.86

66,422.56

41.10%

95,194.30

58.90%

2012 2

2014 12

2013

6.50%

26.35%

2014

12

33,409.67

13,346.44

150.33%

54.22%

2014

7,829.59

68,672.45

42.49%

X53

2013

541.15

0.33%

4,515.39

2.79%

1,096.23

0.68%

	2014	12	31	2013	12	31
			%			%
	16,113.37		30.78%	12,376.37		31.50%
	1,695.46		3.24%	460.37		1.17%
	3,281.77		6.27%	1,158.27		2.95%
	2,955.99		5.65%	622.75		1.59%
	37.13		0.07%	51.78		0.13%
	1,491.21		2.85%	308.15		0.78%
	7,600.00		14.52%	1,750.00		4.45%
	41,868.90		79.98%	16,727.69		42.58%
	8,045.16		15.37%	21,895.16		55.73%
	1,526.27		2.92%	663.19		1.69%
	907.56		1.73%	-		-
	10,478.99		20.02%	22,558.35		57.42%
	52,347.89		100.00%	39,286.04		100.00%

	2014	12	31	52,347.89
41,868.90			79.98%	10,478.99
20.02%				
16,113.37			30.78%	X53
			7,600.00	14.52%
	1,695.46		3.24%	3,281.77
	6.27%		2,955.99	5.65%
			0.07%	37.13
			1,491.21	2.85%

		8,045.16	15.37%
1,526.27		2.92%	
3			
2014	12	31	32.39%

	2014	12	31	2013	12	31
			32.39%			31.58%
/			41.10%			43.16%
/			58.90%			56.84%
/			79.98%			42.58%
/			20.02%			57.42%
			1.59			3.21
			1.35			2.93

2014

2013

25% 31%

1

	2014	2013
	53,697.08	34,363.02
	53,697.08	34,363.02
	37,522.73	21,836.47
	20,495.66	12,660.63
	523.53	382.72

	4,131.15	3,788.62
	10,326.70	5,464.57
	961.08	-694.89
	1,084.61	234.82
	16,174.36	12,526.55
	629.09	300.96
	23.92	1.66
	16,779.53	12,825.85
	2,407.52	1,818.65
	14,372.01	11,007.20
	12,828.13	11,007.20

2014 53,697.08 16,779.53

12,828.13

2014 2013 16.54%

39.14%

6,686.18 2014 10,326.70 2013

5,464.57 88.98% 961.08 2013 -694.89

1,655.97 X53

X53

2

2014

2013

2013 97.69% 2014 96.98%

	2014	2013
	14.16%	13.66%
	7.94%	8.85%
	26.76%	32.03%
	61.84%	63.16%
/	3.61%	2.33%
/	14.35%	14.18%
/	96.98%	97.69%

1

2012 10

C27

GB/T4754-2011

C2760

2

1

IVD In-Vitro Diagnosis

		PCR	PCR	

	1 2
	3 4
	5 7
	6 8
	1 2 3 6
	4 5 8
	7 9 10
	11
	1 2

2

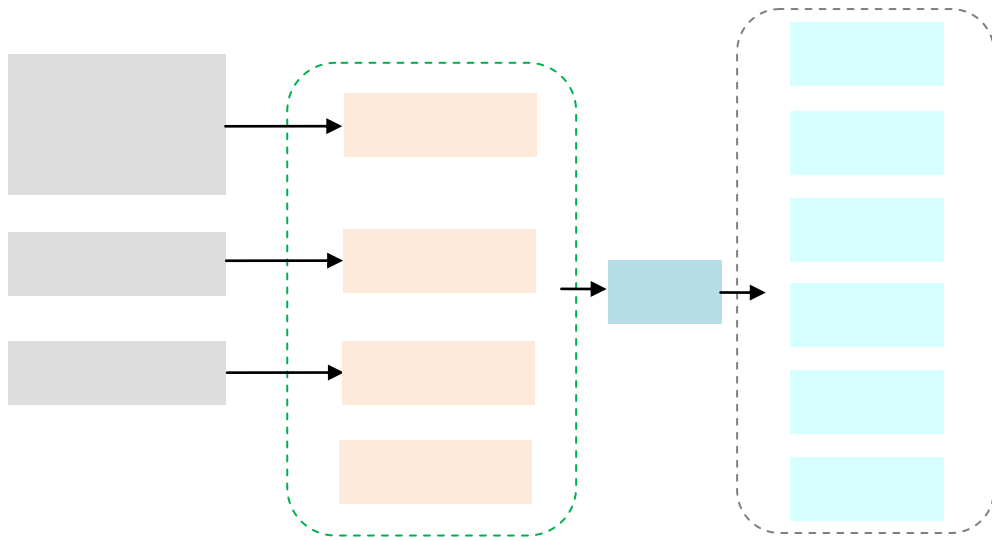

3

	α	α	γ

	MB
	A-1/B

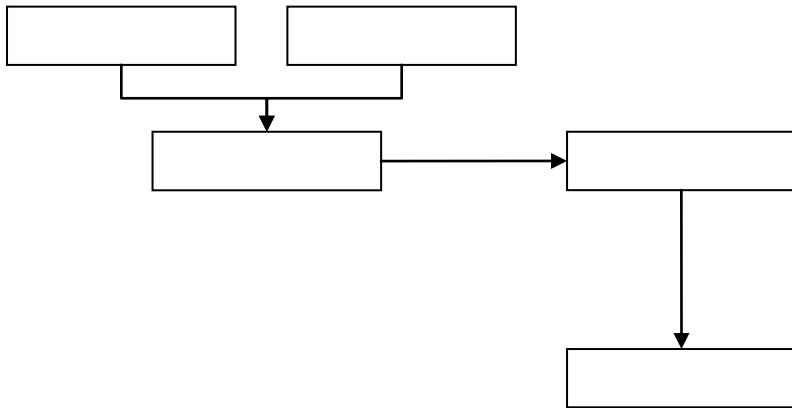

4

1%

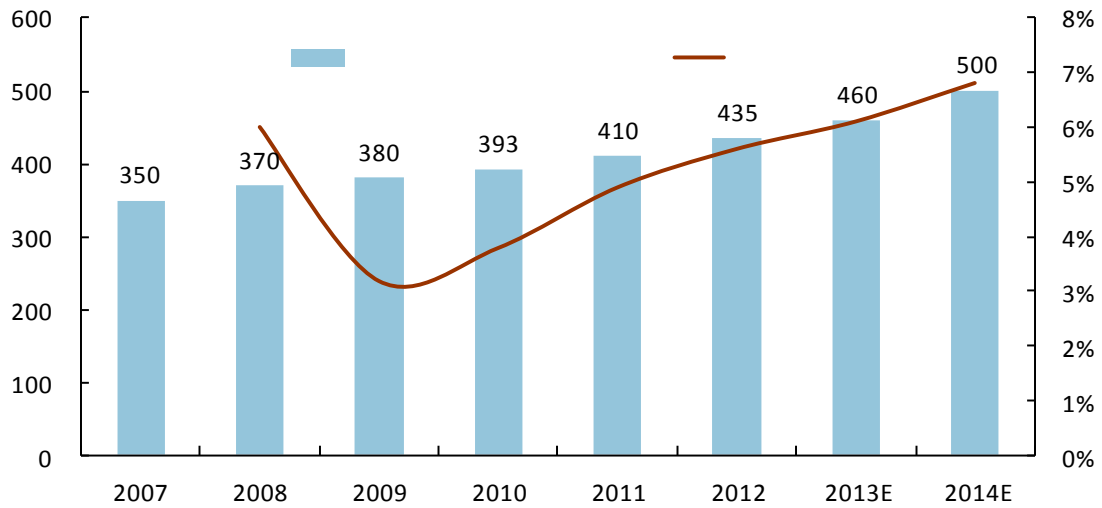

McEvoy&Farmer

McEvoy&Farmer

IVD

	2009	2010		380
393		2009	OECD	Organization for Economic of
Co-operation and Development	30			18%
72%	80%	ROW	Rest of the World	170
82%		28%	20%	OECD
28	ROW	2.5		
5%-6%		2%	ROW	10%

3

1

2005.12		PCR	ELISA
2006.2	2006-2020		
2007.1	2007		
2009.4		90%	8,500
2009.6			
2010.10	2015		8% 15% 2020
2010.10	2010.10		200 1,000
863			
2010.10			

2010.10			
2011	2011.3		
	2011.3		
	2011.7	, 150	, 20
	2011.11		,
	2012.12.29		2015
		4000	
	2012.1		,
	2		
	276	2000 4 1	
	12	2004 7 20	
		2007 4 28	
			100,000

[2007]239			
[2007]229	2007 6 1		
[2007]240	2007 6 1		1,000 200
[2007]299	2007 6 1		
[2009]320	2009 6 15		
[2009]833	2009 12 16		
[2012]1170	2012 5 4		

4

1

20 70

20 50

20 70

20 80

			McEvoy&Farmer	2008-2012
16%	2010		20.7	136.8
		5.7	37.8	
15.0		99	McEvoy&Farmer	
1/5			3%	
1.5			25 30	
			15% 20%	
			20%	
15%				

2007-2014

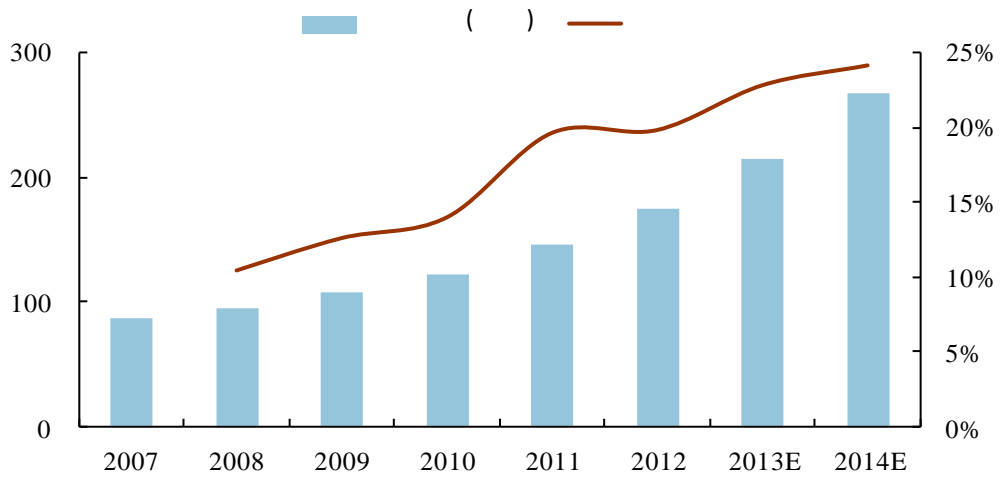

McEvoy&Farmer

2

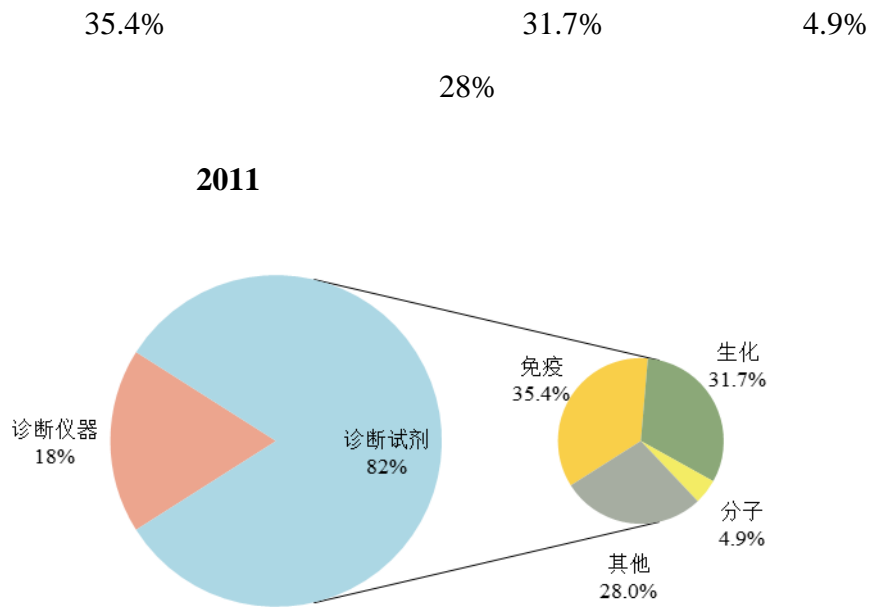

McEvoy&Farmer

32%

50%

2006

2009 -2011

McEvoy&Farmer

2012

47.86

2014

77.15

2007-2014

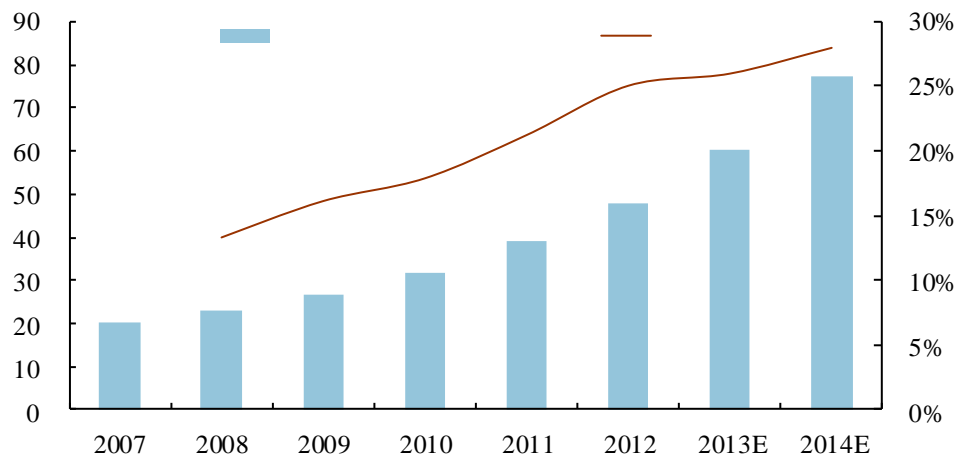

McEvoy&Farmer

3

20

70

2011

1			101.57
2			54.90
3			50.97
4			48.14
5			32.50
6			20.03
7			19.60
8			18.30
9			16.13
10			14.32

Kalorama Information

15%

2013

1			5.44
2			3.93
3			3.81
4			2.93
5			2.34

Wind

4

2012 28,914.4 2011
 18.8% 1999~2012 CAGR 16.3% 2,135.8
 18% 2012
 GDP 5.57% 2011 5.15% 0.42% GDP

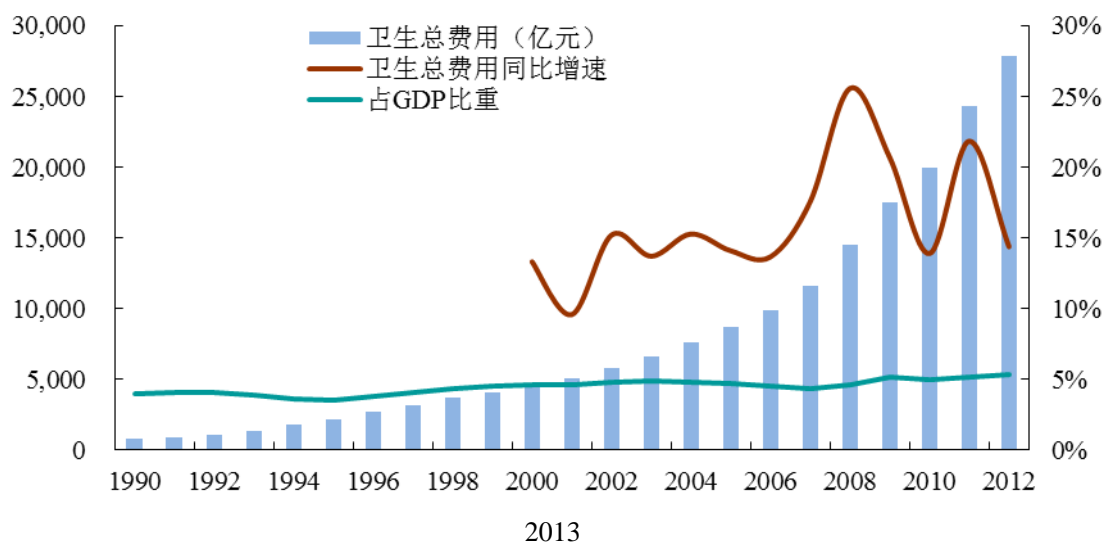

2012 2011
 30.4% 34.7% 34.9% 2000 15.5%
 2011 30.4% 2000 59% 2011
 34.9% WHO2012 /GDP 9.4%
 12.5% 6.1% 2011 GDP
 5.15% 8.8% 9.2% 5.6%
 4.2%

2005 10,493

	2013	26,955		13.1%
2005	3,255	2013	8,896	12.2%

2004-2012

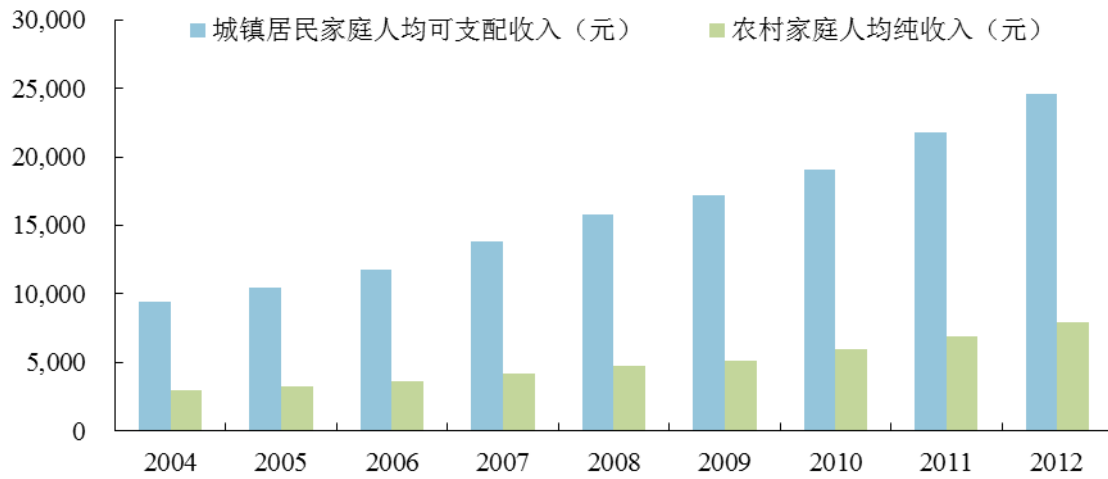

2013

	2000	36.22%	2012
52.3%	2012	2011	1,807.0
2,697.5	879.4		

3

2000-2012

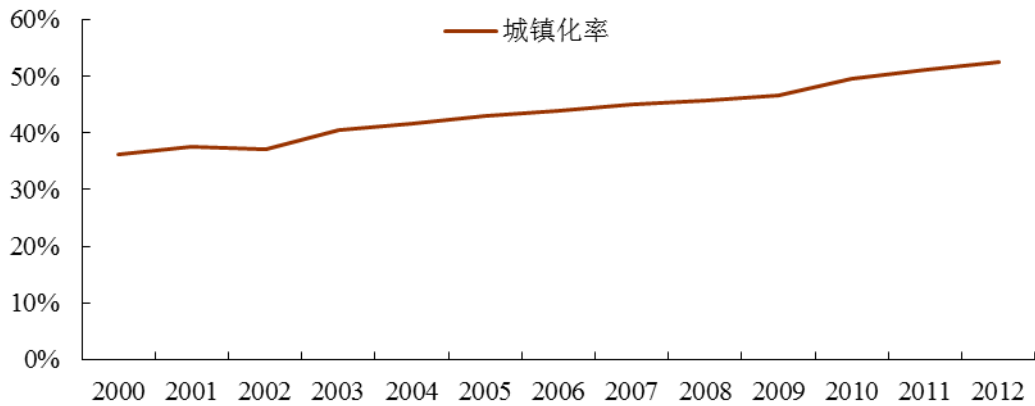

2013

Medical Expenditure Panel Survey

		3-5	2011	4		
		60			1.77	
13.26%	65		1.2		8.87%	2000
	60			2.93		65
	1.91					
			1993	14%	2012	19%
	1993	1.9%	2008	10.7%		1993
11.9	2008	54.9		4	9.7	
		1993	16.98%		2008	19.99%
			2012			68.9
	6.2		9.9%	2013		
73.1			4.2		6.1%	

2004-2012

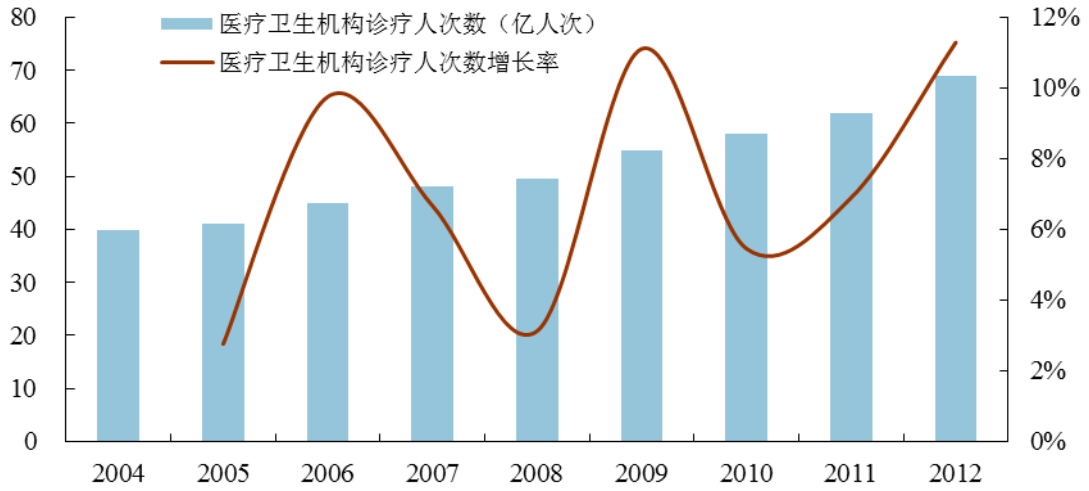

2013

6%-8%

2005

37.8

2011

58

2005-2011

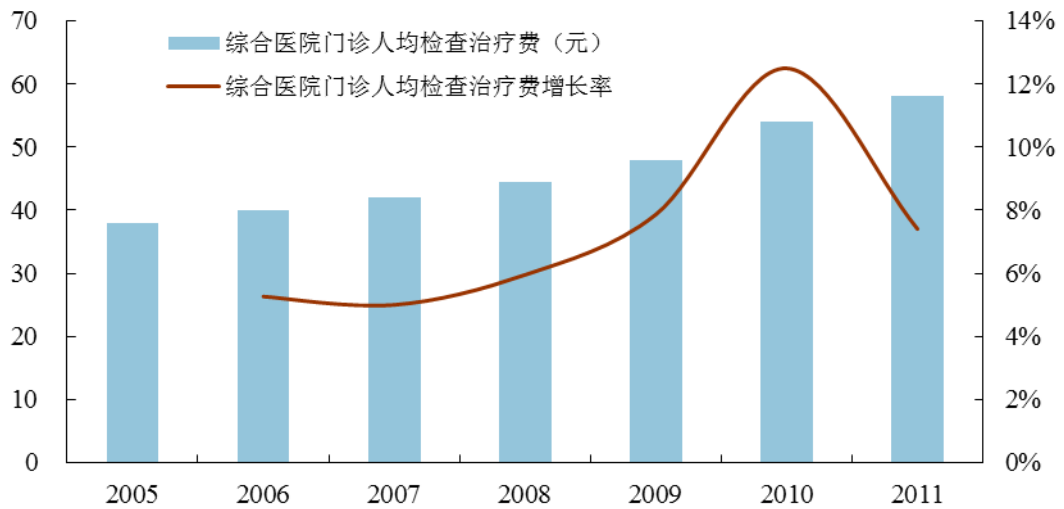

2012

5

1



20

2

2 3

3

4

6

1

2



3

2008

4

7

1

Kalorama Information

2016 27 170
2011

a.

2010 60 13.26% 2000 2.93
65 8.87% 2000 2.93
2011 60 13.7% 65 9.1%
60 10%
65 7%

b.

1993 14% 2012 19%
1993 1.9% 2008 10.7% 1993
1 2008
1993 16.98% 2008 19.99%



2012 5 10

2012

2012 12

2011 3

2011

2009 4

3

90%

2010

120

2009 4

2009-2011

2009-2011

8,500

3,318

2011 4

2011

2011

120

200

2

60%

80%

1

2012-2016
2012 47.86
1.81 2012 3.78%

2

1

80,000 90 2010

475

Genentech
Chugai

2

2010 \$37 87.6%
12.4%

75%

70%

3

Abbott Laboratories 1888

70

1985

1995

Prism

4

/

3

1

1991

CE

1997

DiaSys

DiaSys

2

DiaSys

9

2003

2004

3

ERP

4

50 74% 2009 DiaSys
10% DiaSys 2013 DiaSys
5
DiaSys
5

1997 2001
2004 MEDICA
2007
IFCC PROTEINS DiaSys

6



7

8

9

10



11

4

1

2

3

DiaSys

80%

() (14) S0190

[2015]0710

	2014 12 31	2013 12 31
	50,494,874.52	44,206,997.56
	60,181,833.10	49,399,538.40
	678,031.54	377,875.90
	18,150,086.93	14,377,331.18
	18,278,540.49	9,917,870.00
	776,203.44	-
	148,559,570.02	118,279,613.04
	28,161,973.09	29,312,983.65

	2014 12 31	2013 12 31
	1,027,807.94	736,877.82
	223,615.82	251,789.90
	694,528.31	1,620,566.06
	3,303,075.68	5,283,309.68
	33,411,000.84	37,205,527.11
	181,970,570.86	155,485,140.15
	-	-
	16,512,448.42	10,009,888.44
	1,366,979.65	1,489,787.99
	19,730,000.00	19,097,600.06
	6,543,746.29	9,186,033.01
	33,005,000.00	-
	1,559,511.93	7,266,029.02
	-	360,000.00
	78,717,686.29	47,409,338.52
	970,000.00	-
	-	270,000.00
	970,000.00	270,000.00
	79,687,686.29	47,679,338.52
	9,233,850.00	9,233,850.00
	2.20	2.20
	45,399,250.00	30,529,979.27
	47,649,782.37	68,041,970.16
	102,282,884.57	107,805,801.63

	2014 12 31	2013 12 31
	181,970,570.86	155,485,140.15

1

	2014 12 31	2013 12 31
	76.07%	81.64%

1

	2013 12 31	2014 12 31
	50,494,874.52	44,206,997.56
	14.22%	

2

	2013 12 31	2014 12 31
	60,181,833.10	49,399,538.40
		21.83%

2014

	2015 3 31	2014 12 31
		84.27%

3

	2013 12 31	2014 12 31	2015 3 31
	18,150,086.93	14,377,331.18	
		16,100,000.00	
			9,000,000.00

4

	2014	12	31		18,278,540.49
84.30%				2014	

2014

2014

5

	2013	12	31		29,312,983.65	2014
12				28,161,973.09	3.93%	

2

	2013	12	31		47,679,338.52		
				99.43%	2014	12	31
				98.78%			

1

	2013	12	31		10,009,888.44	2014
12				16,512,448.42	2013	64.96%

2

	2013	12	31		19,097,600.06	2014
12	31			19,730,000.00		3.31%
3						
	2013	12	31		0	
			II		2014	6 30
5,000				2014	6 30	
						2014 12
31				33,005,000.00		
33,005,000.00						
3						

		2014	12	31	2013	12	31	2012	12	31
	+			2,286,919.26			1,553,474.97			23,720.20
	+			3,585.25			482,163.68			124,471.68

4

1

	2014	12	31	2013	12	31
				1.89		2.49
				1.66		2.29
				43.79%		30.66%
				75,596,458.06		50,616,940.60

	2014 12 31	2013 12 31
	NA	86.57
	40,362,210.11	49,382,410.33

= /

= - /

= + + + +

= + + / 2014

1

2013 2014 12 31

2014

2013

2013 86.57 2014

2

2013 49,382,410.33 2014

40,362,210.11

2

	2014	2013
	3.91	4.59
	15.19	21.66

= *2/ +

= *2/ +

1
2014 / 2013
2014
2013
2

	2014	2013
	214,100,186.68	212,132,748.14
	85,087.54	-
	214,185,274.22	212,132,748.14

1

	2014	2013
	214,100,186.68	212,132,748.14

	214,100,186.68	212,132,748.14
--	-----------------------	-----------------------

2013 2014

2

	2014	2014 %	2013	2013 %
	123,106,992.38	57.50%	123,037,866.93	58.00%
	87,984,208.14	41.09%	86,042,093.33	40.56%
	3,008,986.16	1.41%	3,052,787.88	1.44%
	214,100,186.68	100.00%	212,132,748.14	100.00%

3

	2014	2014 %	2013	2013 %
	214,100,186.68	100.00%	212,132,748.14	100.00%
	214,100,186.68	100.00%	212,132,748.14	100.00%

2013 2014

2014

2013

2014

2014

	2012	2013	2014	2014
	3,439.44	3,792.77	3,370.21	422.56
	1,011.06	1,111.04	856.89	254.15
	1,160.73	1,480.29	1,238.41	241.88

4

2013 2014

2012

	2014		2013		2012	
	12,310.70	57.50%	12,303.79	58.00%	10,921.21	59.38%
	8,798.42	41.09%	8,604.21	40.56%	7,157.27	38.92%
	300.90	1.41%	305.28	1.44%	313.31	1.70%
	21,410.02	100.00%	21,213.27	100.00%	18,391.79	100.00%

	2014	2013	2012
	53.77%	51.64%	41.81%
	56.42%	53.01%	47.30%
	29.76%	24.35%	25.71%

	54.52%	51.80%	43.67%
--	---------------	---------------	---------------

IVD

1

2

1997

28

300

1

	2014	2013
	214,100,186.68	212,132,748.14
	85,087.54	-
	214,185,274.22	212,132,748.14

2014

2013

2

	2014	2013
	97,442,185.01	102,246,904.31

2014

2013

3

	2014	2013
	17,770,880.62	19,148,898.78
	28,046,929.53	42,772,738.69
	-71,156.98	296,249.79

	2014	2013
	214,185,274.22	212,132,748.14
	97,442,185.01	102,246,904.31
	54.51%	51.80%
	214,100,186.68	212,132,748.14
	97,365,176.23	102,246,904.31
	54.52%	51.80%

2014

2014

2013

() (14) S0191

[2015]0711

	2014 12 31	2013 12 31
	10,373,274.30	11,500,321.77
	21,268,937.27	3,354,513.93
	1,743.00	268,705.32
	202,046.10	665,839.20
	9,040,238.05	11,639,899.70
	202,340.42	100,512.39
	41,088,579.14	27,529,792.31

	2014 12 31	2013 12 31
	2,006,086.64	1,965,888.08
	95,000.00	-
	2,101,086.64	1,965,888.08
	43,189,665.78	29,495,680.39
	-	5,000,000.00
	4,152,167.39	2,427,662.68
	-	62,812.57
	380,000.00	-
	633,700.92	-559,129.84
	16,125,752.50	5,421,897.83
	21,291,620.81	12,353,243.24
	-	-
	21,291,620.81	12,353,243.24
	3,405,774.31	3,405,774.31
	-	-
	6,203,850.74	5,014,948.79
	12,288,419.92	8,721,714.05
	21,898,044.97	17,142,437.15
	43,189,665.78	29,495,680.39

1

	2013 12 31	
2014 12 31		93.33%
95.14%		

1									
		2013	12	31		11,500,321.77		2014	
12	31				10,373,274.30		2013	12	31
					9.98%				
2									
		2013	12	31		3,354,513.93		2014	
12	31				21,268,937.27		534.04%		
	2014				HANSS				
90									
HANSS					HANSS				
2014									
			2015	3	31	2014	12	31	
									99.72%
3									
		2013	12	31		11,639,899.70		2014	12
31					9,040,238.05		22.33%		
2									
						2013	12	31	
12,353,243.24		2014	12	31		21,291,620.81			
1									
		2013	12	31		2,427,662.68		2014	
12	31				4,152,167.39		2013	71.04%	
								2013	

2014

2

2013 12 31 5,421,897.83 2014
12 31 16,125,752.50 197.42%

2014

3

4

1

	2014 12 31	2013 12 31
	1.93	2.23
	1.51	1.29
	49.30%	41.88%
	7,150,715.99	6,673,657.87
	35.38	31.79
	-6,427,869.02	6,931,479.06

= /

= - /

$$= + + + +$$

$$= + + /$$

1

2013 2014

2014

2013

2

2013 6,931,479.06 2014

-6,427,869.02

2

	2014	2013
	6.40	12.04
	7.62	7.47

$$= *2/ +$$

$$= *2/ +$$

1

2014

2014

2014

2013

2014

2014

2

1

	2014	2013
	77,012,418.99	74,499,696.74
	77,012,418.99	74,499,696.74

2013 2014

2

	2014	2014 %	2013	2013 %
	46,014,672.59	59.75%	46,720,289.28	62.71%
	30,972,994.54	40.22%	27,686,013.94	37.16%
	24,751.86	0.03%	93,393.52	0.13%
	77,012,418.99	100.00%	74,499,696.74	100.00%

3

	2014	2014 %	2013	2013 %
	35,190,967.50	45.70%	72,680,697.22	97.56%
	41,821,451.49	54.30%	1,818,999.52	2.44%
	77,012,418.99	100.00%	74,499,696.74	100.00%

2013

97.56%

2013 10

2014

HANSS

2014

54.30%

4

2012

2013 2014

	2014		2013		2012	
	4,601.47	59.75%	4,672.03	62.71%	4,103.75	53.26%
	3,097.20	40.22%	2,768.60	37.16%	3,577.53	46.43%
	2.48	0.03%	9.34	0.13%	23.96	0.31%
	7,701.24	100.00%	7,449.97	100.00%	7,705.24	100.00%

	2014	2013	2012
	21.12%	18.14%	13.52%
	10.35%	8.78%	14.12%
	-7.90%	-37.04%	15.73%
	16.70%	14.59%	13.81%

IVD

1

2

1997

28

300

1

	2014	2013
	78,786,715.76	75,058,588.17

2014

2013

2

	2014	2013
--	-------------	-------------

	65,132,454.59	64,057,046.83
--	---------------	---------------

2014

2013

3

	2014	2013
	-	-
	5,199,245.00	5,048,475.16
	2,373,421.98	85,762.98
	7,572,666.98	5,134,238.14

2014

2013

4

	2014	2013
	78,786,715.76	75,058,588.17
	65,132,454.59	64,057,046.83
	17.33%	14.66%

2014

2014

2013

1

100

DiaSys

20%

50

74%

2009

10%

300

2014

12,828.13

5,942.33

475.56

2014 ~2017

5,516

6,342

6,977

7,674

[2014]3137

2015

17,400.66

88,741.18

2014

2

	2014 12 31	2013 12 31
	32.39%	31.58%
	1.59	3.21
	1.36	2.93

[2015]1550 2013 12
31 2014 12 31

	2014 12 31	2013 12 31
	27.29%	33.50%
	1.59	1.63
	1.36	1.46

2014 12 31 27.29%
32.39%

2014 12 31 1.59 1.36



1

2



3

4

IVD

5



6

IVD

7

8

IVD

1

2014

	2014 12 31	/2014
	161,616.86	191,663.39
	96,451.11	134,221.47
	53,697.08	69,509.49
	16,779.53	21,474.95
	12,828.13	16,539.50
/	0.84	0.97

2014

0.84 / 2014

0.97

/

2

3

4

1,000

2015

2014

2015

1,000

IVD

2012 2013
 () (14) S0190

2013 12 31 2012 12 31 2013
 2012

2014
 [2015]0710

2014 12 31 2014

1

	2014 12 31	2013 12 31	2012 12 31
	148,559,570.02	118,279,613.04	94,412,513.50
	33,411,000.84	37,205,527.11	34,439,131.40
	181,970,570.86	155,485,140.15	128,851,644.90
	78,717,686.29	47,409,338.52	57,016,165.35
	970,000.00	270,000.00	510,000.00
	79,687,686.29	47,679,338.52	57,526,165.35
	102,282,884.57	107,805,801.63	71,325,479.55
	0	0	0
	102,282,884.57	107,805,801.63	71,325,479.55

2

	2014	2013	2012
	214,185,274.22	212,132,748.14	183,917,914.29
	97,442,185.01	102,246,904.31	103,594,127.30
-	68,678,746.90	43,609,859.63	38,935,430.92
-	71,672,909.84	46,350,430.72	39,892,145.06
-	59,423,340.01	41,480,322.08	33,390,244.00
	59,423,340.01	41,480,322.08	33,390,244.00

3

	2014	2013	2012
	40,362,210.11	49,382,410.33	40,117,135.75
	(2,079,333.15)	490,690.60	(6,439,700.39)
	(31,995,000.00)	(29,499,347.72)	(19,987,615.67)
	-	-	-
	6,287,876.96	20,373,753.21	13,689,819.69
	44,206,997.56	23,833,244.35	10,143,424.66
	50,494,874.52	44,206,997.56	23,833,244.35

2012 2013

() (14) S0191

2013 12 31 2012 12 31

2013 2012

2014

[2015]0711

2014 12 31

2014

1

	2014 12 31	2013 12 31	2012 12 31
	41,088,579.14	27,529,792.31	31,683,557.23
	2,101,086.64	1,965,888.08	2,177,434.72
	43,189,665.78	29,495,680.39	33,860,991.95
	21,291,620.81	12,353,243.24	14,438,302.28
	0	0	0
	21,291,620.81	12,353,243.24	14,438,302.28
	21,898,044.97	17,142,437.15	19,422,689.67
	0	0	0
	21,898,044.97	17,142,437.15	19,422,689.67

2

	2014	2013	2012
	78,786,715.76	75,058,588.17	77,052,359.53
	65,132,454.59	64,057,046.83	66,414,202.08
-	6,054,235.78	5,771,323.35	7,327,823.20
-	6,360,892.27	6,004,345.74	7,556,606.43
-	4,755,607.82	4,481,499.80	5,639,639.90
	4,755,607.82	4,481,499.80	5,639,639.90

3

	2014	2013	2012
--	-------------	-------------	-------------

	(6,427,869.02)	6,931,479.06	7,172,627.91
	(627,366.10)	(280,272.29)	(915,795.48)
	5,928,187.65	(8,706,590.01)	(6,466,275.67)
	-	-	-
	(1,127,047.47)	(2,055,383.24)	(209,443.24)
	11,500,321.77	13,555,705.01	13,765,148.25
	10,373,274.30	11,500,321.77	13,555,705.01

2014 9-12 2015

() (14) E0126

2014 9-12 2015

()

(14) E0127

2012 2013

2014 1 1 8 31

2012

2013 2014 1 1 8 31



1

2

3

2

14

1

	2014			2015
	1-8	9-12		
	14,149.46	9,185.15	23,334.60	26,468.70
	4,437.84	1,944.17	6,382.02	7,419.41
	4,602.15	1,944.17	6,546.32	7,419.41
	3,726.16	1,652.55	5,378.71	6,306.50
	3,726.16	1,652.55	5,378.71	6,306.50

2

	2014			2015
	1-8	9-12		
	5,110.39	3,143.41	8,253.80	9,182.14
	201.49	302.32	503.81	757.59
	203.35	302.32	505.67	757.59
	150.46	226.74	377.20	568.19
	150.46	226.74	377.20	568.19

2015

2014 9-12
[2014]3137

2014 2015

1 2013 1 1
70.00%

2 2013 2014
2015 2014 2015

3

4

2014 2015

1

2

3

4

5

6

7

8

9

10

	2014			2015
	1-8	9-12		
	37,524.49	38,929.82	76,454.32	88,741.18
	8,988.93	11,214.61	20,203.54	22,805.25
	9,359.14	11,227.36	20,586.50	22,842.66
	7,621.22	9,629.89	17,251.11	19,281.25
	6,453.32	9,253.41	15,706.74	17,400.66

2014

[2015]1550

2014

1

2014 1 1



					2014
			26		
2014		[2014]54			
2	2014				
		[2015]0706			2014
					[2015]0710
		[2015]0711			
				1	
3					
		34,059.00			
34,059.00					27.35
/	12,453,016		34,059.00		
4				2014	8 31
				2014	1 1
				2014	1 1
			1		
	2014	1 1			
5					
2014					
1					

	1,252,408,294.02		
			1,342,214,736.58
			51,295,531.37
			1,393,510,267.95
	1,916,633,874.38		1,916,633,874.38

2014

	695,094,892.64
	695,094,892.64
	487,701,154.54
	272,000,610.50
	6,499,413.77
	52,989,691.94
	132,804,848.15
	11,828,697.68
	11,577,892.50
-	207,393,738.10
	7,616,162.29
	6,343.58
	260,403.19
	43,542.05
-	214,749,497.20
	31,177,218.72
-	183,572,278.48
	165,394,956.09
	18,177,322.39

	183,572,278.48
	165,394,956.09
	18,177,322.39



-31.38B39[<1D5C243002C5>Tj <

2		
3		
4		5%
5		5%
6		5%
7		5%
8		5%
9		5%
10		
11		5%
12		5%
13		
14		
15		
16		
17		
18		
19		
20		
21		

2

2012

[2013]0518

2013

[2014]0807

2014

[2015]0706

/

1

/

				2014	2013	2012
				-	2,578,359.85	-
				27,471.13	-	-
				27,471.13	2,578,359.85	-
				21,253,102.76	-	-
				13,540,598.93	-	-
				1,240,590.09	-	-
				36,034,291.78	-	-

2

		2014 12 31	2013 12 31	2012 12 31
		8,673,772.41	-	-
		-	147.60	-
		5,916,930.90	-	-
		9,461,757.20	-	-
		628,337.86	-	-

3

2014 11 24

() (14) S0190 ()

(14) S0191

[2015]0710

[2015]0711

1

2015 12 31

	2014 9 57%
	22%
Günther Gorka	
	25%

			2014		2013		2012	
				(%)		(%)		(%)
			27.51	0.13	105.63	0.50	154.47	0.84
			-	-	-	-	531.69	2.89
			435.35	2.03	314.67	1.48	-	-
			462.87	2.16	420.30	1.98	686.16	3.73

			3,732.69	35.28	7,323.96	73.26	7,561.47	73.43
			1,646.53	15.56	1,201.70	12.02	1,233.85	11.98
			-	-	-	-	0.58	0.01
			1,878.32	17.75	209.38	2.09	46.88	0.46
			2,504.69	23.67	99.89	1.00	-	-
			9,762.22	92.27	8,834.92	88.37	8,842.78	85.88
			-	-	30.92	25.62	-	-

2013 2 8

	2014		2013		2012	
/()						
	-	-	(674.98)	532.43	(146.63)	1,207.41
	-	-	806.22	806.22	-	-
	-	-	(345.00)	-	-	345.00
	-	-	(213.76)	1,338.65	(146.63)	1,552.41

		2014 12 31	2013 12 31	2012 12 31
		0.02	-	85.46
		-	130.45	-
		0.02	130.45	85.46
		1,610.00	532.43	1,207.41

		-	806.22	-
		-	-	345.00
		1,610.00	1,338.65	1,552.41
		237.45	169.69	380.62
		131.98	328.51	874.63
		124.40	116.87	-
		946.18	-	-
		1,440.01	615.06	1,255.25
		-	-	800.00
		-	400.00	-
		62.83	58.11	58.11
	Günther Jans	1.64	46.87	46.87
		-	-	3.49
		64.47	504.99	908.47

2

		2014	9 100%
		30%	
			31%

			2014	2013	2012

				(%)				
						(%)		(%)
			3,732.68	47.38	7,323.96	97.58	7,561.47	98.13
			3,038.42	38.57	154.36	2.06	40.20	0.52
			16.19	0.20	26.87	0.36	45.16	0.59
			6,787.29	86.15	7,505.19	100	7,646.83	99.24
			27.51	0.44	105.63	1.64	154.47	2.44
			5,428.57	86.81	5,401.69	84.00	5,039.35	79.74
			294.85	4.72	329.88	5.13	81.24	1.29
			43.20	0.69	30.49	0.47	-	-
			5,794.13	92.67	5,867.69	91.24	5,275.06	83.47
			41.41	56.7	100.22	85.44	-	-

	2014		2013		2012	
I()						
			(674.98)	532.43	(146.63)	1,207.41

		2014 12 31	2013 12 31	2012 12 31
		131.98	334.79	874.63
		867.38	-	37.15

		-	-	-
		999.36	334.79	911.78
		-	-	3.49
	Günther Jans	-	40.51	-
		-	40.51	3.49
		-	-	6.35
		0.02	-	85.46
		354.24	55.79	40.94
		-	141.85	-
		354.25	197.64	126.40
		1,610.00	532.43	1,207.41
		-	6.28	-

3

2014 2012 2013

				2014		2013		2012	
					(%)		(%)		(%)
				16,465,310.89	15.56	12,017,032.84	12.02	12,338,500.36	11.98

				18,783,160.33	17.75	2,093,787.42	2.09	468,812.47	0.46
				-	-	309,226.48	25.62	-	-

2014

2014

2013

2012

2013

2014

				2014		2013		2012	
					(%)		(%)		(%)
				30,384,204.92	38.57	1,543,635.56	2.06	401,964.30	0.52
				161,870.77	0.20	268,734.22	0.36	451,552.69	0.59
				54,285,658.85	86.81	54,016,877.26	84.00	50,393,498.29	79.74
				2,948,545.21	4.72	3,298,794.08	5.13	812,443.28	1.29

				431,955.36	1.05	304,943.51	0.47	-	-
				414,067.81	56.70	1,002,244.93	85.44	-	-

2013 10

2014

HANSS

2014

2014

HANSS

2013

1	24.97	5.53	-19.44	-77.85%
2	9.63	4.00	-5.63	-58.46%
3	9.10	1.68	-7.42	-81.54%
4	6.39	2.64	-3.75	-58.69%
5	33.30	8.55	-24.75	-74.32%
6	8.46	5.02	-3.44	-40.66%
7	8.27	3.15	-5.12	-61.91%

8	16.28	6.29	-9.99	-61.36%
9	4.19	2.04	-2.15	-51.31%
10	10.20	2.64	-7.56	-74.12%
11	47.11	27.46	-19.65	-41.71%
12	11.75	4.85	-6.9	-58.72%
13	9.09	4.51	-4.58	-50.39%
14	6.24	3.49	-2.75	-44.07%
15	48.16	14.04	-34.12	-70.85%

1	1.96	1.96	0.00%
2	0.28	0.28	0.00%
3	3.79	3.79	0.00%
4	0.21	0.21	0.00%
5	0.42	0.42	0.00%
6	0.21	0.21	0.00%
7	5.40	5.40	0.00%

15%

15%

a.

1	0.1915	0.3292
2	54.3869	72.54
3	1.9379	3.0888
4	1.0886	2.1481
5	1.2776	3.4866

b.

	1	3,055.69	2,935.61	-120.08	-3.93%
	2	358.80	278.50	-80.30	-22.38%
	3	659.14	624.52	-34.62	-5.25%
	4	395.64	324.98	-70.66	-17.86%
	5	55.43	48.37	-7.06	-12.74%
	6	4,121.94	4,114.90	-7.04	-0.17%
	7	3,219.78	3,189.53	-30.25	-0.94%
	8	1,630.75	1,640.45	9.70	0.59%
	9	592.68	522.00	-70.68	-11.93%
	10	475.83	438.13	-37.70	-7.92%
	11	410.55	301.11	-109.44	-26.66%
	12	593.04	540.79	-52.25	-8.81%
	13	1,549.96	1,421.70	-128.26	-8.28%
	14	62.19	54.11	-8.09	-13.01%
	15	52.40	26.18	-26.23	-50.06%
	16	43.12	41.95	-1.17	-2.71%
	17	188.51	176.64	-11.87	-6.30%

	18	105.81	102.12	-3.69	-3.49%
	1	3,249.15	2,935.61	-313.54	-9.65%
	2	652.28	624.52	-27.77	-4.26%
	3	339.99	324.98	-15.02	-4.42%
	4	4,244.18	4,114.90	-129.28	-3.05%
	5	3,362.52	3,189.53	-172.99	-5.14%
	6	1,724.36	1,640.45	-83.91	-4.87%
	7	468.17	438.13	-30.04	-6.42%
	8	327.51	301.11	-26.40	-8.06%
	9	566.27	540.79	-25.48	-4.50%
	10	1,442.57	1,421.70	-20.87	-1.45%
	11	64.58	54.11	-10.47	-16.22%
	12	46.74	41.95	-4.79	-10.24%
	13	196.45	176.64	-19.81	-10.09%
	14	118.46	102.12	-16.33	-13.79%

Alpha-Amylase CC FS

4%

c.

	2014 1-6	2013	2012
	46.63%	48.75%	49.17%
	50.16%	48.92%	55.41%
	60.35%	63.16%	62.30%
	65.49%	67.19%	70.32%
	78.68%	77.43%	77.66%
	42.46%	44.55%	43.78%
	53.94%	56.16%	49.15%

1

2

/

3

/

2



9

3

3

2

www.cninfo.com.cn



[2007]128

		2014 8 31	100%
	13,006.74	75,415.26	
479.82%	100%	1,864.70	6,105.12
	227.40%		

-10% 10%

10%	89,265.90	0.18	7,238.52	0.19
5%	82,340.58	0.09	6,671.82	0.09
0%	75,415.26	0.00	6,105.12	0.00
-5%	68,489.94	-0.09	5,538.42	-0.09
-10%	61,564.62	-0.18	4,971.73	-0.19

2014 ~2017 5,516

6,342 6,977 7,674

2014

5,942.33

475.56

2014 9 11
49.53%

2014 9 11

20%

10,703.56

10,703.56



20

DiaSys

DiaSys



25%

31%



1

80%

2

3

DiaSys

DiaSys

/



			2012	2013	2014	
			2.89	14.43	-19.73	
2012	2013	2014				-5.52
	10.73	-217.59				
	2005	7				

20%

3-5

1-2



98%

2011 12 6

15%

2014 12 6

3

2014

2014 2016

15%

2017

			2013			
			2013		1,200	
	II			2014	6	30
5,000			2014	6	30	
						2014
	1,699.50					

0.8%





2014 9 11

25%

100% 70,400

70% 492,478,217.10

25% 24% 13.5%

7.5%

2014 9 12

25%

25%

31%

		%			
1		9	63,360,000	63,318,627.91	
		5	35,200,000	35,177,015.51	
		13.5	95,040,000	94,977,941.87	
		7.5	52,800,000	52,765,523.26	
2		12	84,480,000	84,424,837.22	
		7	49,280,000	49,247,821.71	
3		7	49,280,000	49,247,821.71	
4		3	21,120,000	21,106,209.30	
5		3	21,120,000	21,106,209.30	
6		3	21,120,000	21,106,209.30	

2014 9 19

[2014] 939

2014 9 22

[1999]1498

2014 9 23

310000400229163

2014 12 31

70%

1		30.00		25.00%
2		28.80		24.00%
3		26.40		22.00%

4		16.20		13.50%
5		9.00		7.50%
6		6.00		5.00%
7		3.60		3.00%
		120.00		100.00%

31%

2014 9 11

100% 6,100

70% 4,270

31% 30% 9%

31%

2014 9 12

25%

31%

31%

		%			
1		31	18,910,000.00	18,910,000.00	
		30	18,300,000.00	18,300,000.00	
		9	5,490,000.00	5,490,000.00	

2014 9 16

No.007587

2014 9 18

310000400229163

2014 12 31

70%

1		15.50		31.00%
2		15.00		30.00%
3		15.00		30.00%
4		4.50		9%
		50.00		100.00%

2014 10

15

1

10

/3

/

/ 3



1

80%

2

3

DiaSys

2

1

IVD

IVD

20%

IVD

2

DiaSys

IVD

28

300

3

1

1

40

1999

1	
2	
3	
4	()
5	()
6	
7	IFCC
8	
9	(2,4-)
10	- ()
11	
12	
13	()
14	
15	(2,4-)
16	
17	
18	
19	- (EPS-G7)
20	- ()
21	
22	
23	
24	

20%

2014

2015 3

3

2015

2

2010

β 2

CE

HDL

HDL

HDL

3

2008

	1995	
Chiba University, Medical School		
1995~1998	La Jolla	
Howard Grey	1999	1999~2000
2001~2008		
Kirin Pharma USA,		
Novartis		
2008		

1995

P450
 1998-2001
 2001-2003

	2	1	2008
	2009	2010-2012	β 2
	2013-2014		2012
			apoA1
			HDL

1

2
4

3
5

2

1	α -	10 kg
2		2000 g
3		50 g
4		1000 g
5	4-	250 g
6		250 g
7	L-	10 kg
8		2500 ml
9		5000 KU
10		50 KU
11	3- -2-	5000 g
12		2000 KU
13		2500 KU
14	N- -D-	5000 g
15	(23)	1000 ml

1

2

3

1997

DiaSys

DiaSys

DiaSys

1

DiaSys

2014 9 11

DiaSys

DiaSys

DiaSys

/

2

2012 3 19

CO-OPERATION AGREEMENT

A

LICENCE AND

DiaSys

2014 9 11

50

7

7

12500	10
1255050)
32500	

18830	
18610	A
18650	B
12511	

3

2015-2017

IVD

IVD



/

/

DiaSys

DiaSys



1

2 DiaSys

DiaSys

DiaSys

DiaSys

3

4
2014 9 11
50

7

DiaSys

7

12500	10
1255050)
32500	
18830	
18610	A
18650	B
12511	

5



DiaSys



/ 45% /

1

2

3

4



1

20%

2

20%

1

2

3

1

2



20%

3

20%

4

2014 8 6

2014 2 5

2014 11 7

5%

18

2014 2 5

2014 11 7

1	2014-06-03		2,000	2,000
2	2014-06-20		9,100	11,100
3	2014-07-14		100	11,000

1

5

2

10%

3

4

/

10%

1	2014-07-23		1,000	1,000
2	2014-07-28		1,000	0
3	2014-07-30		500	500
4	2014-08-01		500	1,000

1

5

2

10%

3

4

/

10%

1	2014-02-27		5,000	5,000
2	2014-03-12		2,000	7,000

1

5

2

10%

3

4

10%

1	2014-06-19		200	200
2	2014-06-26		100	100
3	2014-08-05		100	0

1

2

/



2014 2 24

2014 6 18

2014 7 21

2014

7 21

A

2014 8 6

2014 8 5 28.07 /

21 2014 7 8 27.90 /

20 2014 7 9 2014 8 5



		0.32%		
	20			399102
-0.41%		399618	0.07%	
				399102
	399618			20
	20%			



2014	11	24	2014	
				36
105,245,436			66.9215%	
			23	171,936
		0.1093%		



	2014	0.84 /
	[2015]1550	2014
0.97 /		



()

1

()

()

()

()

()

(2014)

2

(2014

)

3

45%

39%

4

5

6

()

()

7

8

1

2

3

4

5

6

7

8

9

1

2

3

4

5

25%

31%

45%

39%

6

7

8

9

22

A 6

010-56839300

010-56839400

8

20

010-85191300

010-85191350

1

222

30

021-61418888

021-61412012

2

22 1

901-22 901-26

010-66001391

010-66001392

28

F4 939

010-88000156

010-88000006

1	
2	
3	
4	
5	
6	
7	
8	

9

18	[2014]3137
19	2014 1106
20	2014 1107
21	[2015] 0710
22	[2015] 0711
23	[2015]1550
24	
25	
26	
27	

5

010-84923554

010-67856540-8881

22

A 6

010-56839300

010-56839400

<http://www.cninfo.com.cn>

